

2019
223

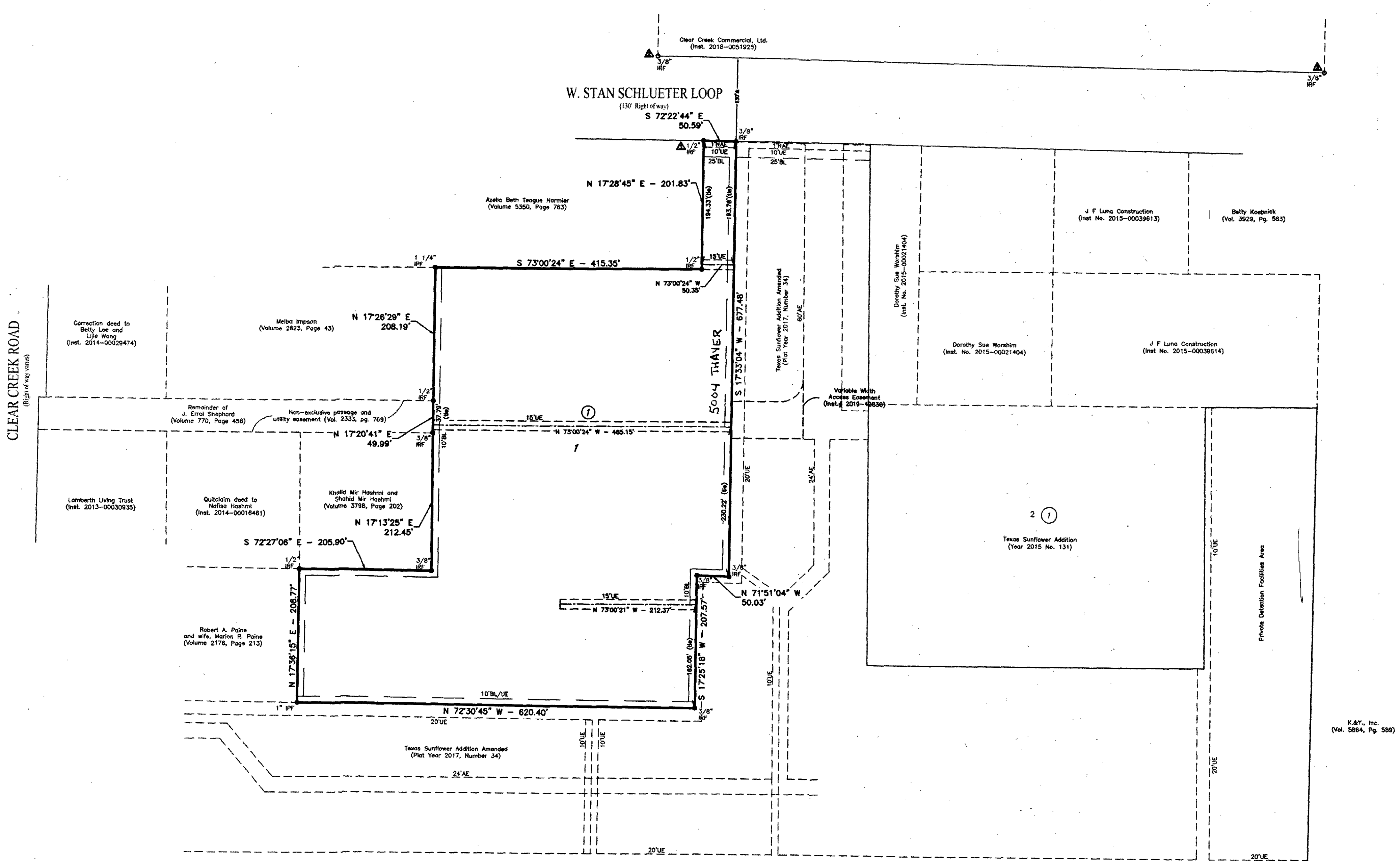
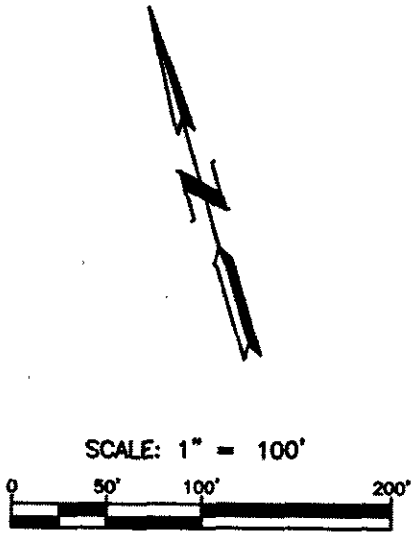

SURVEY NOTES:

- ALL CORNERS SHOWN ARE 3/8" IRON ROD SET WITH KILLEEN ENGINEERING CAP UNLESS OTHERWISE NOTED.
- BEARINGS ARE BASED ON THE TEXAS COORDINATE SYSTEM, CENTRAL ZONE, NAD 83, PER LEICA SMARTNET GPS OBSERVATIONS.
- THIS SUBDIVISION IS LOCATED IN ZONE X, BY THE U.S. FEMA AGENCY BOUNDARY MAP, (FLOOD INSURANCE RATE MAP), MAP NO. 48027C0260E, EFFECTIVE DATE SEPTEMBER 26, 2008 FOR BELL COUNTY, TEXAS.

REFERENCE TIES:

△ TO △ N 11°46'10"W - 150.18'

△ TO △ S 79°51'10"E - 973.55'

KNOW ALL MEN BY THESE PRESENTS, that Lock-It-Down Killeen #1, L.L.C. ("Owner"), whose address is 670 Twicken Avenue, Part Small Addition #2001, being the sole owner of that 8.25 acre tract of land in Bell County, Texas, part of the J.E. Madders Survey, Abstract No. 600, which is more fully described in the dedication of LOCK-IT-DOWN SELF-STORAGE, as shown by the plat hereof, attached hereto, and made a part hereon, and approved by the Planning and Zoning Commission of the City of Killeen, Bell County, Texas, does hereby adopt said LOCK-IT-DOWN SELF-STORAGE, as an addition to the City of Killeen, Bell County, Texas, and hereby dedicates to said city all streets, avenues, roads, drives, and alleys shown on said plat, the same to be used as public thoroughfares and for the installation and maintenance of public utilities when and as authorized by the City of Killeen. The utility and drainage easements shown on said plat are dedicated to said city for installation and maintenance of any and all public utilities and drainage utilities which the city may install or permit to be installed or maintained.

For: Lock-It-Down Killeen #1, L.L.C.
By: *Rick Griffin*
Rick Griffin, Manager

STATE OF ARKANSAS
COUNTY OF SEBASTIAN

This instrument was acknowledged before me on the 21st day of May, 2019, by Rick Griffin, Manager of Lock-It-Down Killeen #1, L.L.C.

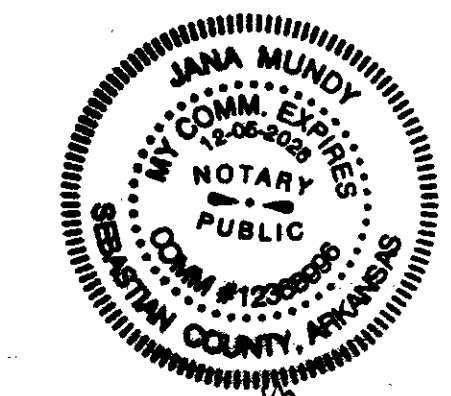

Jana Mundy
Notary Public, State of Arkansas

Approved this 18th day of November, 2019 by the Planning and Zoning Commission of the City of Killeen, Texas.

[Signature]
Chairman, Planning and Zoning Commission

[Signature]
Secretary, Planning and Zoning Commission

FILED FOR RECORD this 20th day of December 2019 A.D.

Year 2019, Number 223, Plat Records of Bell County, Texas.

Dedication Instrument in Instrument No. 2019-58318, Official Records of Bell County, Texas.

KNOW ALL MEN BY THESE PRESENTS:

That I, Michelle E. Lee, a Registered Professional Land Surveyor, do hereby certify that I prepared this plat from an actual and accurate survey of the land and that the perimeter corner monuments shown hereon were properly placed or found under my personal supervision, in accordance with the Subdivision Regulations of the City of Killeen, Texas. This subdivision, LOCK-IT-DOWN SELF-STORAGE, is located within the City Limits of Killeen, Texas.



Michelle E. Lee 11-6-19
Michelle E. Lee, RPLS (TX 5772)

TAX CERTIFICATE

The Bell County Tax Appraisal District, the taxing authority for all entities in Bell County, Texas does hereby certify that there are currently no delinquent taxes due or owing on the property described by this plat.

Dated this 20th day of November 2019 A.D.

BELL COUNTY TAX APPRAISAL DISTRICT

By: *Jeanne Jackson*

LEGEND	
IRF	IRON ROD FOUND
IPF	IRON PIPE FOUND
NAE	NON-ACCESS EASEMENT
AE	ACCESS EASEMENT
UE	UTILITY EASEMENT
BL	BUILDING LINE
INST.	INSTRUMENT NUMBER

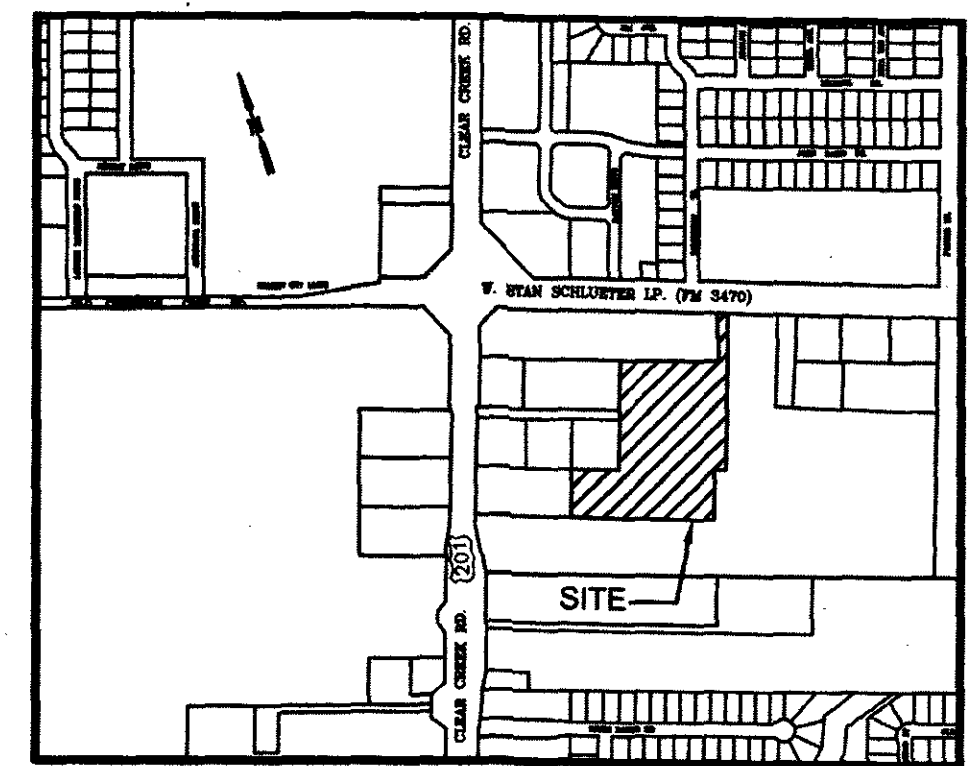

VICINITY MAP
N.T.S.

KILLEEN ENGINEERING & SURVEYING, LTD
2901 E. Stan Schlueter Loop
Killeen, Texas 76542
OFFICE: (254) 526-3981 FAX: (254) 526-4351
TBPLS REGISTRATION NO. F-4200
TBPLS REGISTRATION NO. 10194541

DATE	SHEETS

FINAL PLAT
LOCK-IT-DOWN SELF-STORAGE
KILLEEN, BELL COUNTY, TEXAS

Project No.:	2019-008
Acres:	8.25
No. of Lots:	1
Scale:	1" = 100'
Date:	10/18/2019
Design By:	AEN/BCC
Sheet No.:	1 of 1

Inst# 2019-58318