

FOUR ELEMENTARY SCHOOL ADDITIONS

KILLEEN INDEPENDENT SCHOOL DISTRICT

KILLEEN, TEXAS

~~HAY BRANCH ELEMENTARY SCHOOL~~

~~KILLEEN, TEXAS~~

WILLOW SPRINGS ELEMENTARY SCHOOL

KILLEEN, TEXAS

~~MOUNTAIN VIEW ELEMENTARY SCHOOL~~

~~HARKER HEIGHTS, TEXAS~~

~~DUNCAN ELEMENTARY SCHOOL~~

~~FT. HOOD, TEXAS~~

BOARD OF TRUSTEES

GORDON G. ADAMS

PRESIDENT

JOHN BLANKENSHIP

VICE PRESIDENT

BILL L. TURNER

SECRETARY

DR. RICHARD D. WILSON

JEAN SHINE

JOHN D. HOOVER, JR.

BILL COOKE

DR. CHARLES PATTERSON

SUPERINTENDENT

BLGY INC.

ARCHITECTS

1600 W. 38TH STREET

ENGINEERS

SUITE 100 512-451-8281













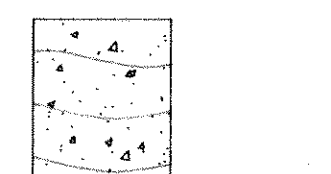
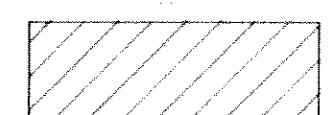

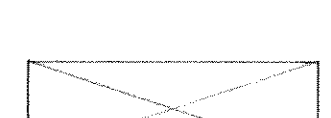
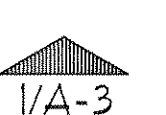
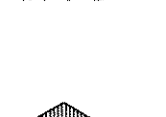
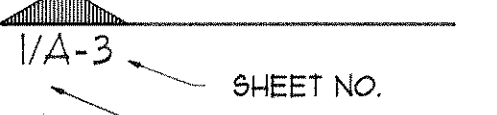
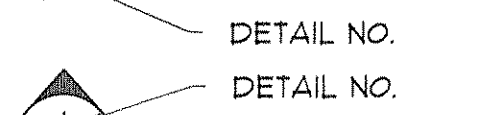

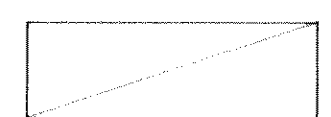
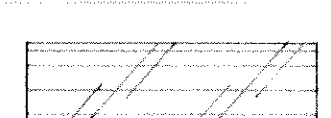
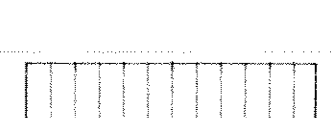
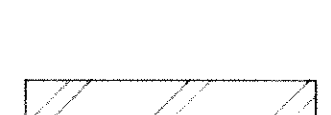
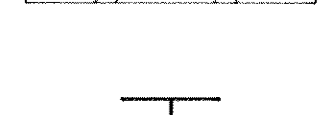

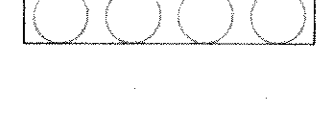
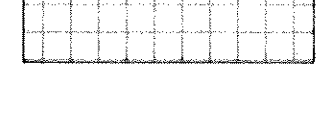
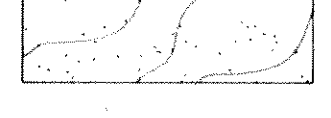
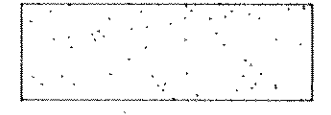

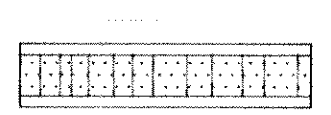
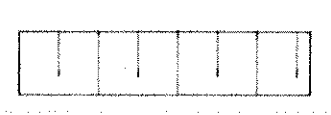
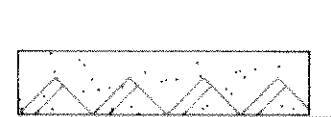



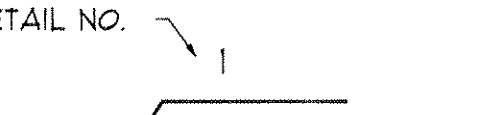

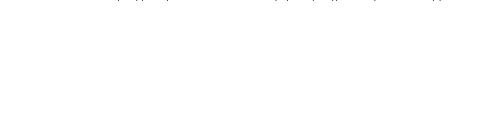
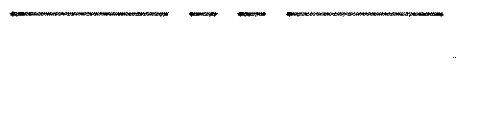
PLANNERS

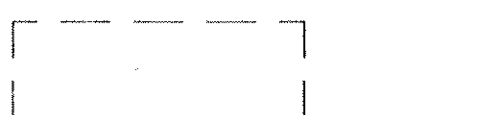
AUSTIN, TEXAS 78731

TALEX INC.
CONSULTING MEP ENGINEERS
AUSTIN, TEXAS

JOSE I. GUERRA INC.
CONSULTING STRUCTURAL ENGINEER
AUSTIN, TEXAS

GENERAL INFORMATION

MATERIALS	SYMBOLS	DESIGN CRITERIA	SHEET INDEX
 EARTH  CONCRETE  MASONRY UNIT (CMU)  BRICK  FINISH WOOD  ROUGH WOOD	 EXTERIOR ELEVATION  INTERIOR ELEVATION  BUILDING SECTION  WALL SECTION  ENLARGED PLAN	<p>HAY BRANCH ELEMENTARY ADDITION WILLOW SPRINGS ELEMENTARY ADDITION MOUNTAIN VIEW ELEMENTARY ADDITION</p> <p>APPLICABLE CODES STANDARD BUILDING CODE, 1988 EDITION, WITH 1989 & 1990 REVISIONS STANDARD MECHANICAL CODE, 1988 EDITION, WITH 1989 & 1990 REVISIONS NATIONAL ELECTRICAL CODE, 1981 EDITION STANDARD PLUMBING CODE, 1988 EDITION, WITH 1989 & 1990 REVISIONS STATE PURCHASING AND GENERAL SERVICES PROGRAM FOR THE ELIMINATION OF ARCHITECTURAL BARRIERS</p> <p>BUILDING AREA EXISTING: 59,156 SF ADDITION: 1,880 SF</p> <p>CONSTRUCTION TYPE EXISTING: TYPE II, UNSPRINKLED ADDITION: TYPE II, UNSPRINKLED</p> <p>OCCUPANCY CLASSIFICATION ADDITION: E-EDUCATIONAL</p>	<p>COVER SHEET GENERAL INFORMATION SHEET</p> <p>ARCHITECTURAL</p> <p>A-11 SITE PLAN - HAY BRANCH A-21 PARTIAL SITE PLANS - HAY BRANCH A-12 SITE PLAN - WILLOW SPRINGS A-22 PARTIAL SITE PLANS - WILLOW SPRINGS A-13 SITE PLAN - MOUNTAIN VIEW A-14 SITE PLAN - DUNCAN A-3 MASTER PLAN A-4 FLOOR PLAN, TOILET PLAN, REFLECTED CEILING PLAN, DEMOLITION PLAN AND PARTIAL PLANS A-5 ROOF PLAN & DETAILS A-6 BUILDING ELEVATIONS & BUILDING SECTIONS A-7 WALL SECTIONS AND DETAILS</p>
 WOOD BLOCKING  PLYWOOD  METAL (ELEVATION)  STRUCTURAL STEEL (LARGE SCALE)  STRUCTURAL STEEL (SMALL SCALE)  BATT OR BLANKET TYPE INSULATION  RIGID INSULATION  STONE (BUILDING MATERIAL)  PLASTER OR STUCCO (ELEVATION DWGS.)  GYPSUM BOARD (LARGE SCALE)  GYPSUM SHEATHING  ACOUSTICAL TILE (LARGE SCALE)  PLASTER WITH METAL LATH  GLASS (LARGE SCALE)  THERMAL GLASS (LARGE SCALE)  WINDOW  CARPET  METAL STUD	 DETAIL (IN DETAIL BOOK)  CENTER LINE DESIGNATION  MATCH LINE  EQUIPMENT (IN CONTRACT)  EQUIPMENT (NOT IN CONTRACT)  PARTITION TYPE  LOUVER TYPE  WINDOW TYPE  ROOM NUMBER  DOOR NUMBER  PROPOSED REFERENCE ELEVATION  EXISTING REFERENCE ELEVATION  COLUMN LINE  FLOOR PLAN  REVISION NUMBER	<p>DUNCAN ELEMENTARY ADDITION</p> <p>APPLICABLE CODES UNIFORM BUILDING CODE, 1988 EDITION UNIFORM MECHANICAL CODE, 1988 EDITION UNIFORM ELECTRICAL CODE, 1988 EDITION UNIFORM PLUMBING CODE, 1988 EDITION LIFE SAFETY CODE, NFPA 101 AMERICANS WITH DISABILITIES ACT</p> <p>BUILDING AREA EXISTING: 59,156 SF ADDITION: 1,880 SF</p> <p>CONSTRUCTION TYPE EXISTING: TYPE II, FIRE RESISTIVE ADDITION: TYPE II, FIRE RESISTIVE</p> <p>OCCUPANCY CLASSIFICATION ADDITION: E-EDUCATIONAL</p> <p>FIRE RATED ASSEMBLIES ROOF/CEILING CONSTRUCTION: U.L. DESIGN NO. P231, 1 1/2 HOURS ROOF STRUCTURE: U.L. DESIGN NO. P231, 1 1/2 HOURS COLUMNS: CONCRETE COLUMNS, 2 HOURS CORRIDOR WALLS: U.L. DESIGN NO. U425, 1 HOUR</p>	<p>STRUCTURAL</p> <p>S-1 FOUNDATION PLAN AND GENERAL NOTES - WILLOW SPRINGS, MOUNTAIN VIEW & DUNCAN S-2 FOUNDATION PLAN AND GENERAL NOTES - HAY BRANCH S-3 FOUNDATION BEAM SCHEDULE AND DETAILS - HAY BRANCH S-4 ROOF FRAMING PLAN AND DETAILS - HAY BRANCH, WILLOW SPRINGS, MOUNTAIN VIEW & DUNCAN</p> <p>MECHANICAL/ELECTRICAL/PLUMBING</p> <p>MPE-1 SITE PLAN MP-2 MECHANICAL AND PLUMBING PLANS MP-3 ROOF PLAN AND SCHEDULES MP-4 DETAILS AND SCHEDULES E-2 POWER AND LIGHTING PLANS E-3 ROOF PLAN AND SCHEDULES</p>
		<p>VICINITY MAP</p> <p>NOTE: REFER TO THE SITE PLAN OF EACH ADDITION FOR THE VICINITY MAPS.</p>	



BLGY ARCHITECTS-ENGINEERS-PLANNERS, INC. 1600 W. 38TH STREET SUITE 100 JEFFERSON BUILDING AUSTIN, TX 78731 (512) 451-8881

FOUR ELEMENTARY SCHOOL ADDITIONS
 INDEPENDENT SCHOOL DISTRICT
 KILLEEN TEXAS

PROJECT NUMBER 9111
 DATE 8 NOV 91
 SHEET A-1
 OF 12

- KEY NOTES**
- 10'-0" UTILITY EASEMENT
 - 25'-0" BUILDING SETBACK
 - 25'-0" STREET & UTILITY EASEMENT
 - 35'-0" ADDITIONAL DEDICATED STREET R.O.W.
 - 240° (E) S 72° 10' 28" E
 - 263° (E) N 03° 44' 27" E
 - 293° S (10 ESMT. E)
 - 170° (10 ESMT. E)
 - 100'-0" T.R. & L. BASEMENT
- △ ALL EASEMENTS & SETBACKS

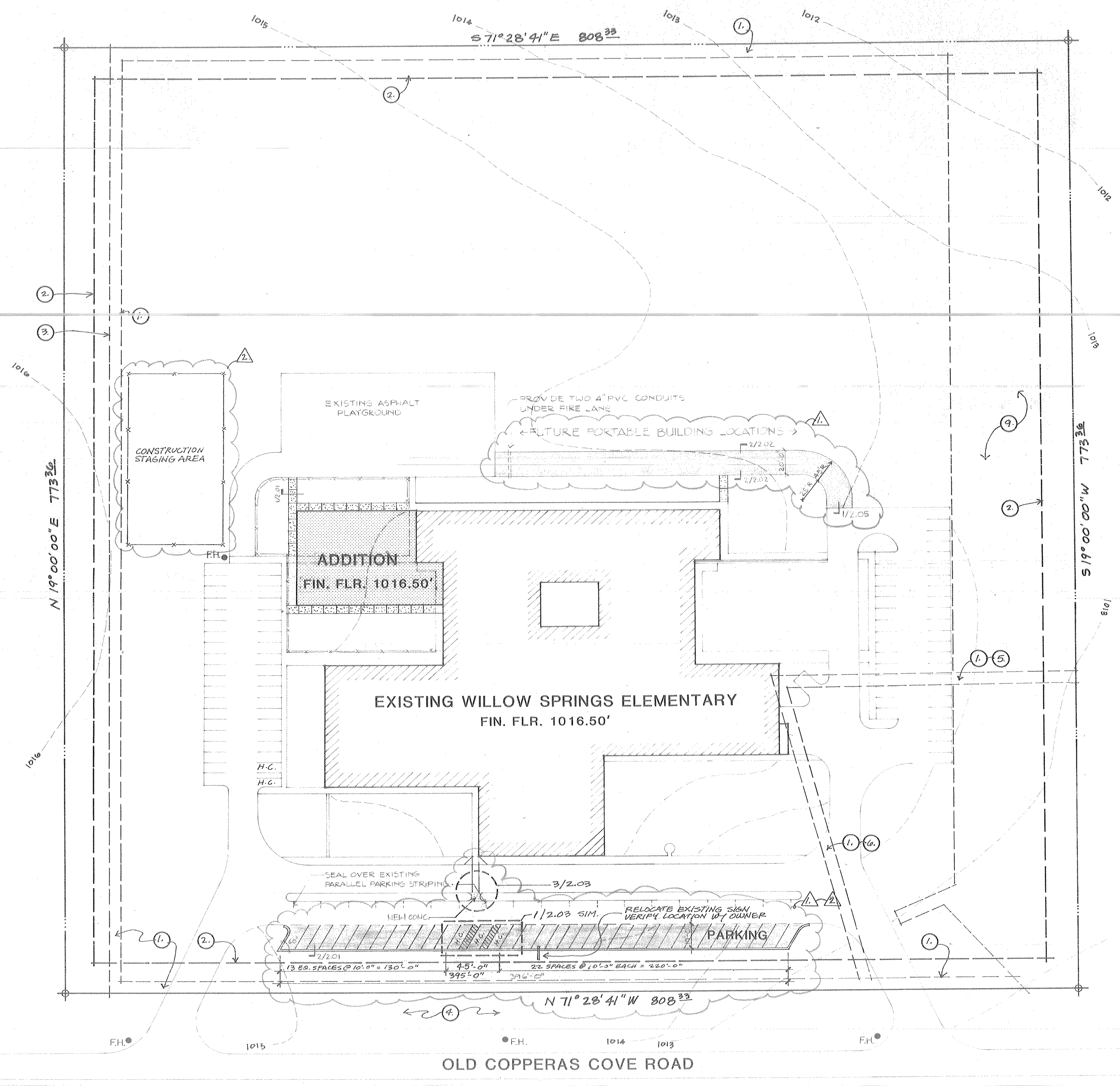

SITE PLAN

SCALE: 1" : 50'-0"

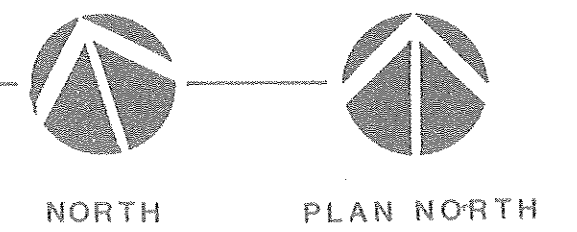

SITE PLAN LEGEND

- NEW BUILDING
- EXIST. TO REMAIN
- EXIST. TO BE REMOVED
- NEW CONC. WALKWAY
- EXIST. GRADES
- NEW GRADES
- NEW ASPHALT PAVING
- 6'-0" HIGH CHAIN LINK CONSTRUCTION FENCE

GENERAL NOTES:

- Existing portable classroom buildings to be relocated by Owner.
- Emergency exiting through the addition from the existing school must be maintained during all phases of construction.
- Maintain construction fencing throughout construction period. All material storage to be within construction fencing.
- Maintain clear passage at Fire Lane during construction.
- Schedule work on new parking so as not to interfere with morning drop-off and evening pick-up of students.

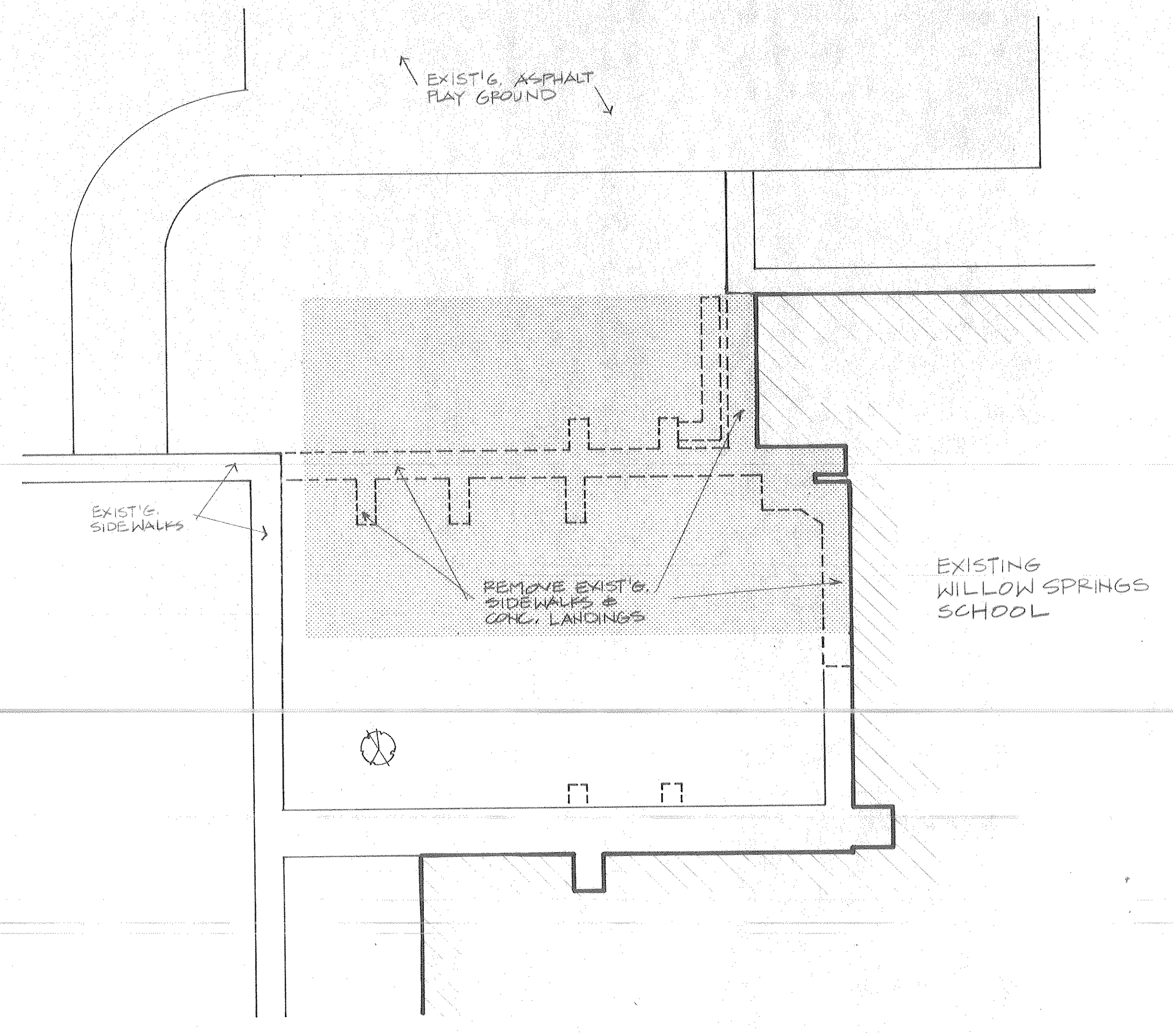

DEMO PLAN
SCALE: 1" : 20'-0"

LOCATION MAP

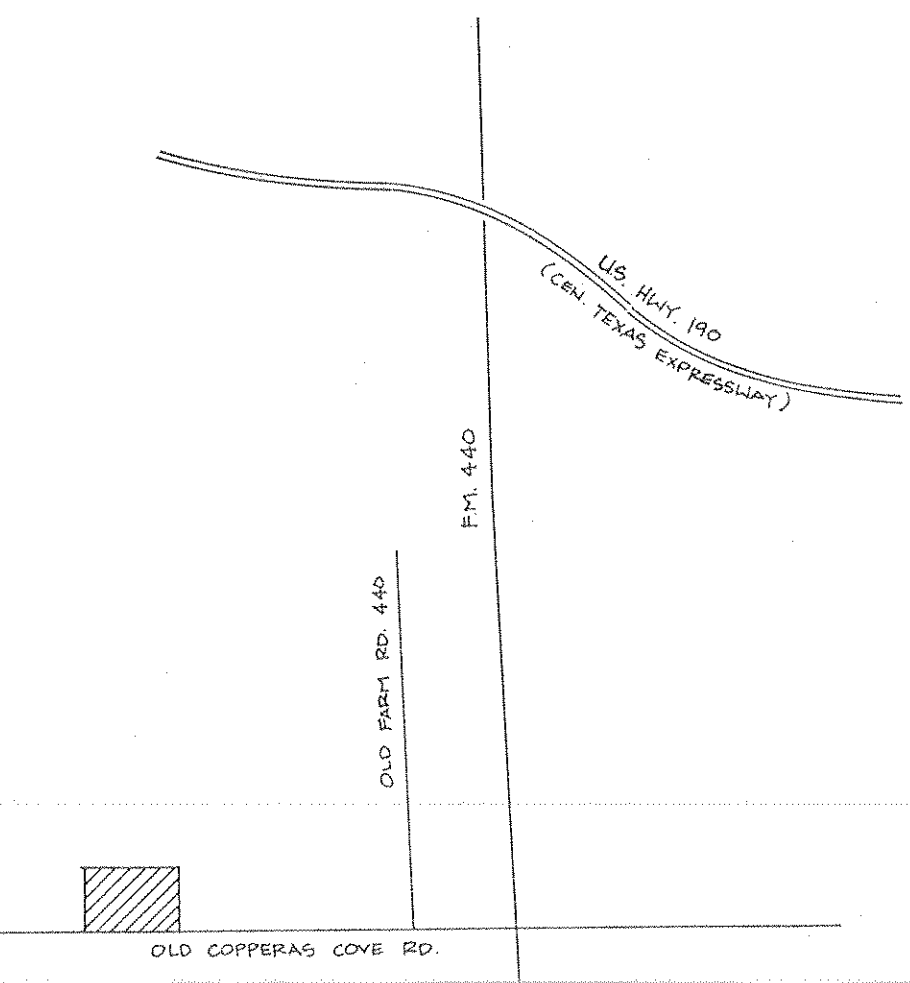

ADDENDUM 1 NOV. 25, 1991
CITY OF HILLEN REVISIONS DEC. 16, 1991

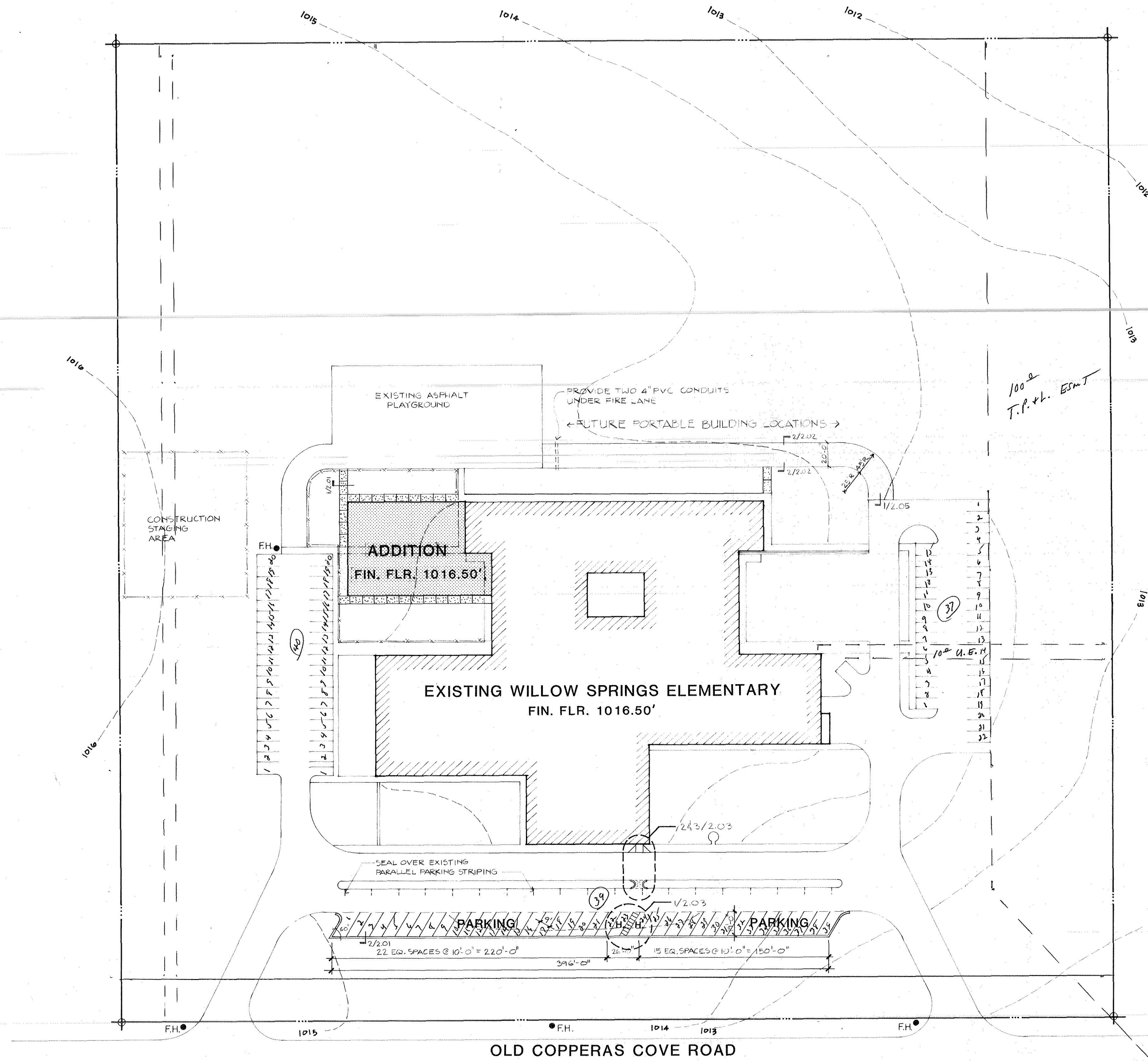

SITE PLAN

SCALE: 1" : 50'-0"

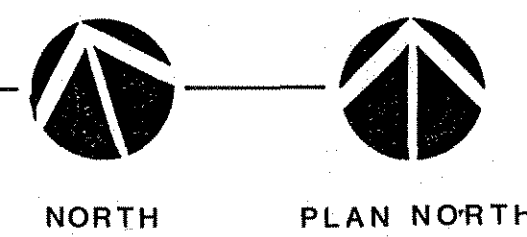

SITE PLAN LEGEND

- NEW BUILDING
- EXIST. TO REMAIN
- EXIST. TO BE REMOVED
- NEW CONC. WALKWAY
- EXIST. GRADES
- NEW GRADES
- NEW ASPHALT PAVING
- 6'-0" HIGH CHAIN LINK CONSTRUCTION FENCE

GENERAL NOTES:

1. Existing portable classroom buildings to be relocated by Owner.
2. Emergency exiting through the addition from the existing school must be maintained during all phases of construction.
3. Maintain construction fencing throughout construction period. All material storage to be within construction fencing.
4. Maintain clear passage at Fire Lane during construction.
5. Schedule work on new parking so as not to interfere with morning drop-off and evening pick-up of students.

DEMO PLAN

SCALE: 1" : 20'-0"

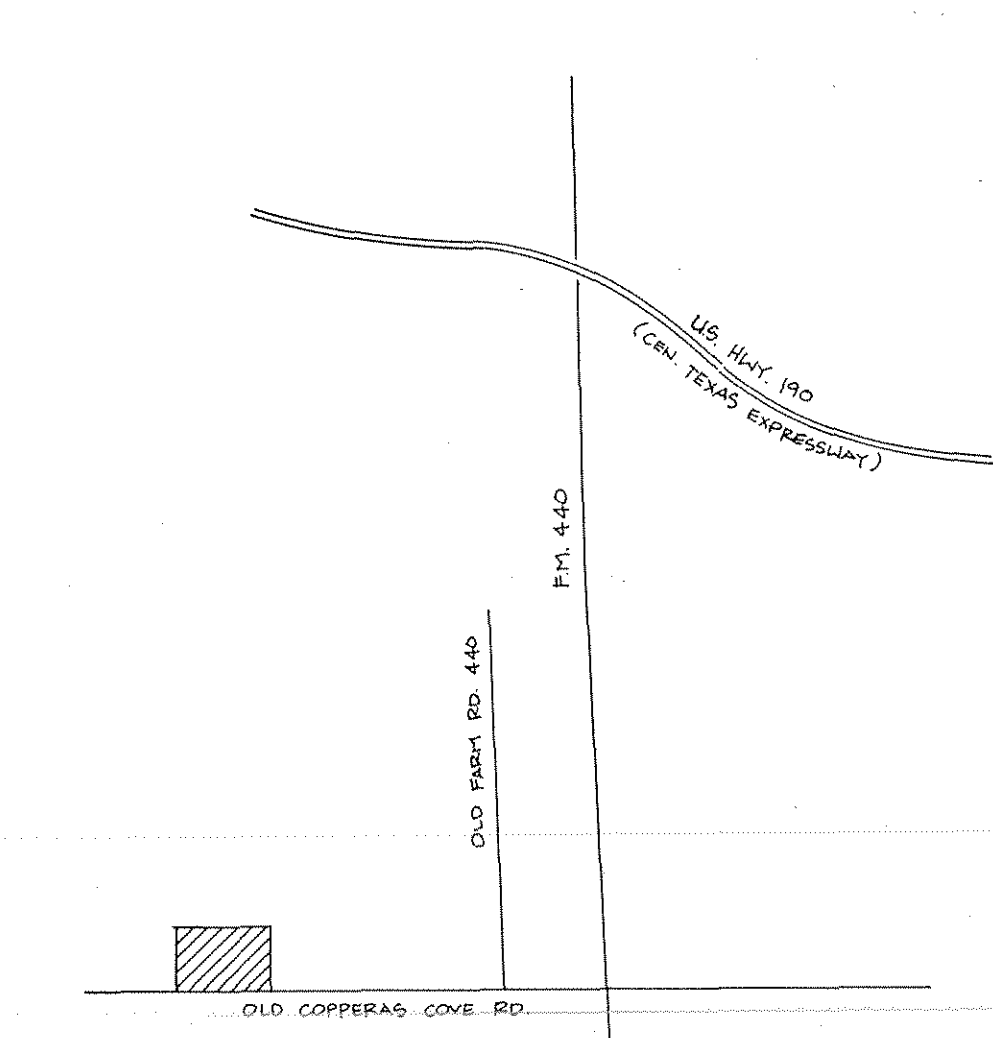
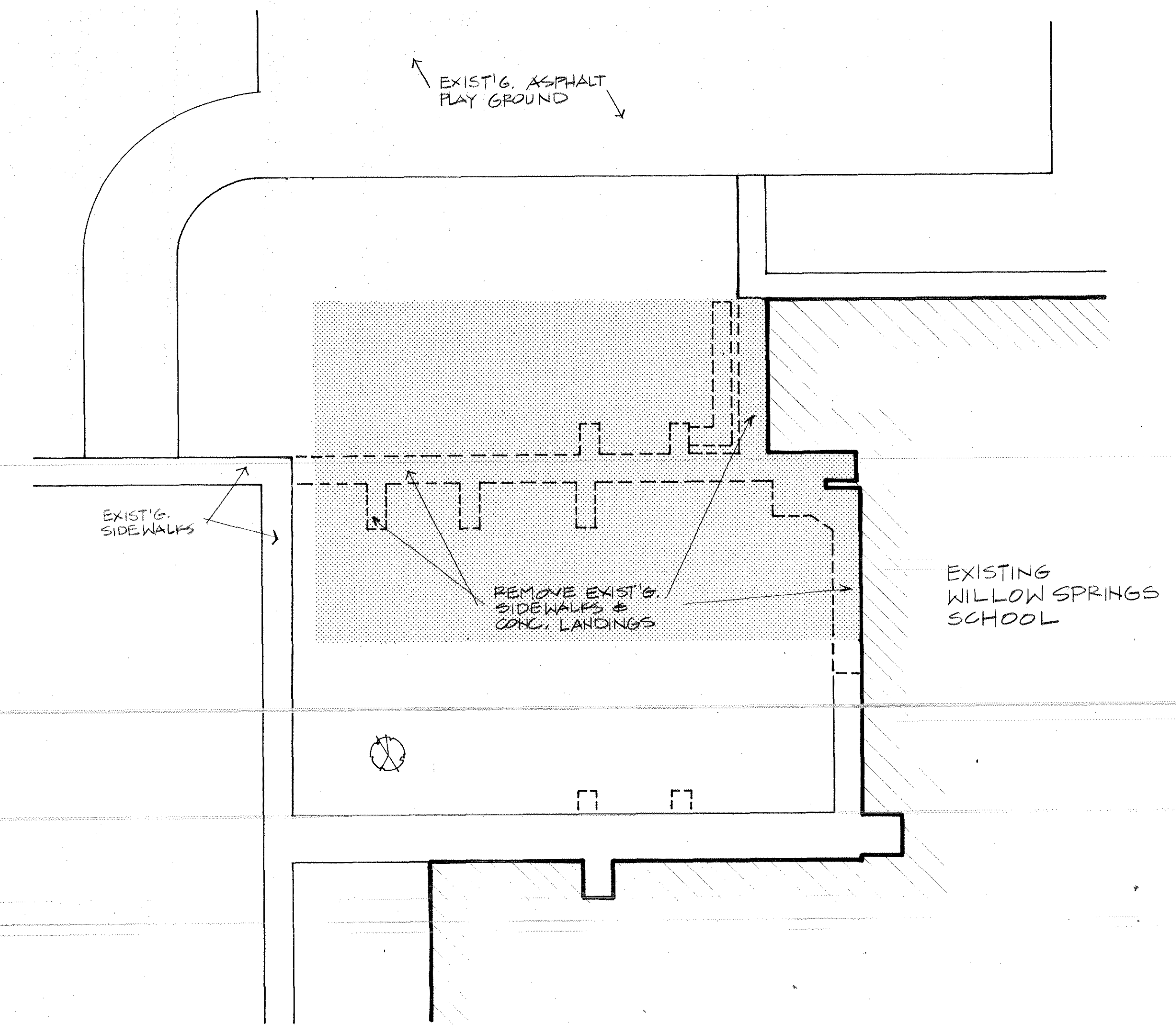

LOCATION MAP

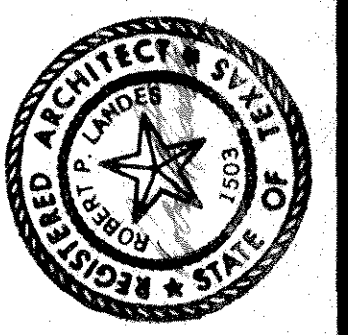

BLGY
INCORPORATED
ARCHITECTS-ENGINEERS-PLANNERS 1800 W. 38TH STREET SUITE 100 JEFFERSON BUILDING AUSTIN, TX 78731 (512) 451-8881

FOUR ELEMENTARY
SCHOOL ADDITIONS
INDEPENDENT SCHOOL DISTRICT
TEXAS
KILLEEN

PROJECT NUMBER 9111
DATE 8 NOV. 91

SHEET
A-1.2
OF 12

WILLOW SPRINGS

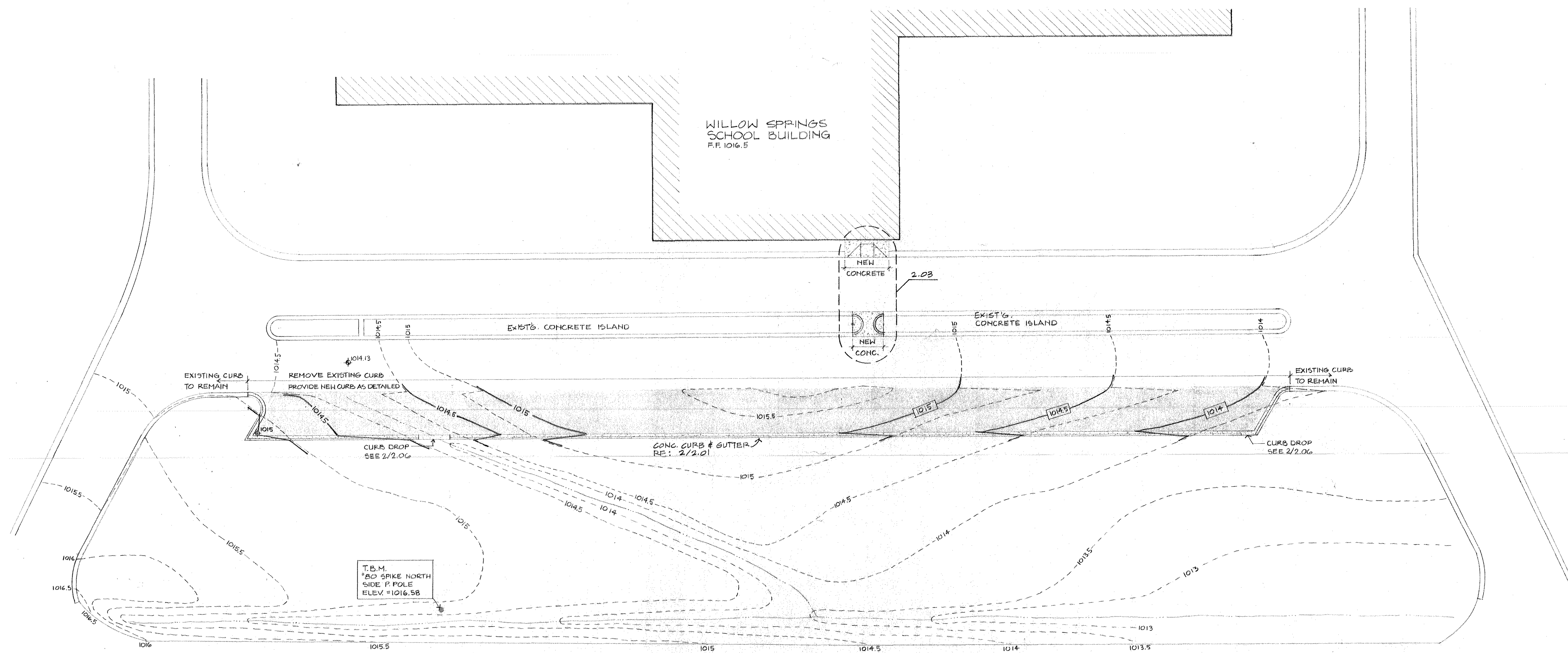

LEGEND

	NEW ASPHALT PAVING
	NEW CONCRETE
	EXISTING GRADE & ELEVATION
	NEW GRADE & ELEVATION
	TRENCH BOTTOM
	EXISTING SPOT ELEVATION
	NEW SPOT ELEVATION
	EXISTING BUILDING

① PARTIAL SITE PLAN
SCALE: 1" = 20'-0"

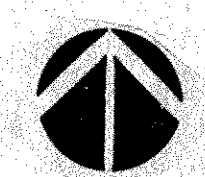

BLGY
INCORPORATED
ARCHITECTS-ENGINEERS-PLANNERS
1600 W. 38TH STREET SUITE 100 JEFFERSON BUILDING AUSTIN, TX 78731 (512) 451-8881

FOUR ELEMENTARY SCHOOL ADDITIONS
KILLEEN INDEPENDENT SCHOOL DISTRICT
KILLEEN TEXAS

PROJECT 9111
DATE 8 NOV. 91

SHEET
A-2.2
OF 12

WILLOW SPRINGS

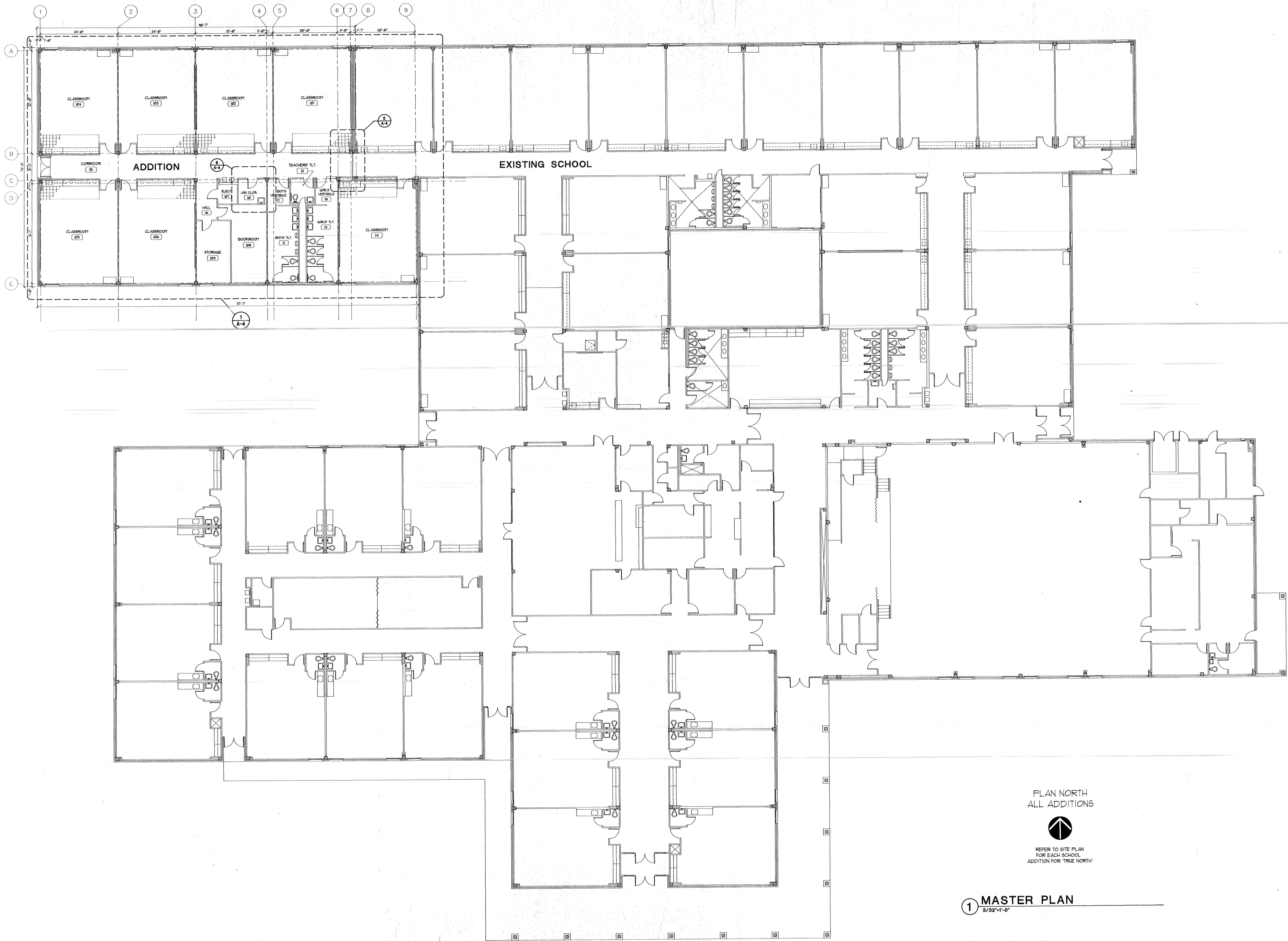

1 MASTER PLAN
3/32"=1'-0"



B.L.G.
INCORPORATED
ARCHITECTS-ENGINEERS-PLANNERS
1600 W. 38TH STREET SUITE 100 JEFFERSON BUILDING AUSTIN, TX 78731 (512) 451-8261

FOUR ELEMENTARY
SCHOOL ADDITIONS
KILLEEN INDEPENDENT SCHOOL DISTRICT
TEXAS

PROJECT NUMBER 9111
DATE 8 Nov 71

SHEET
A-3
OF 12

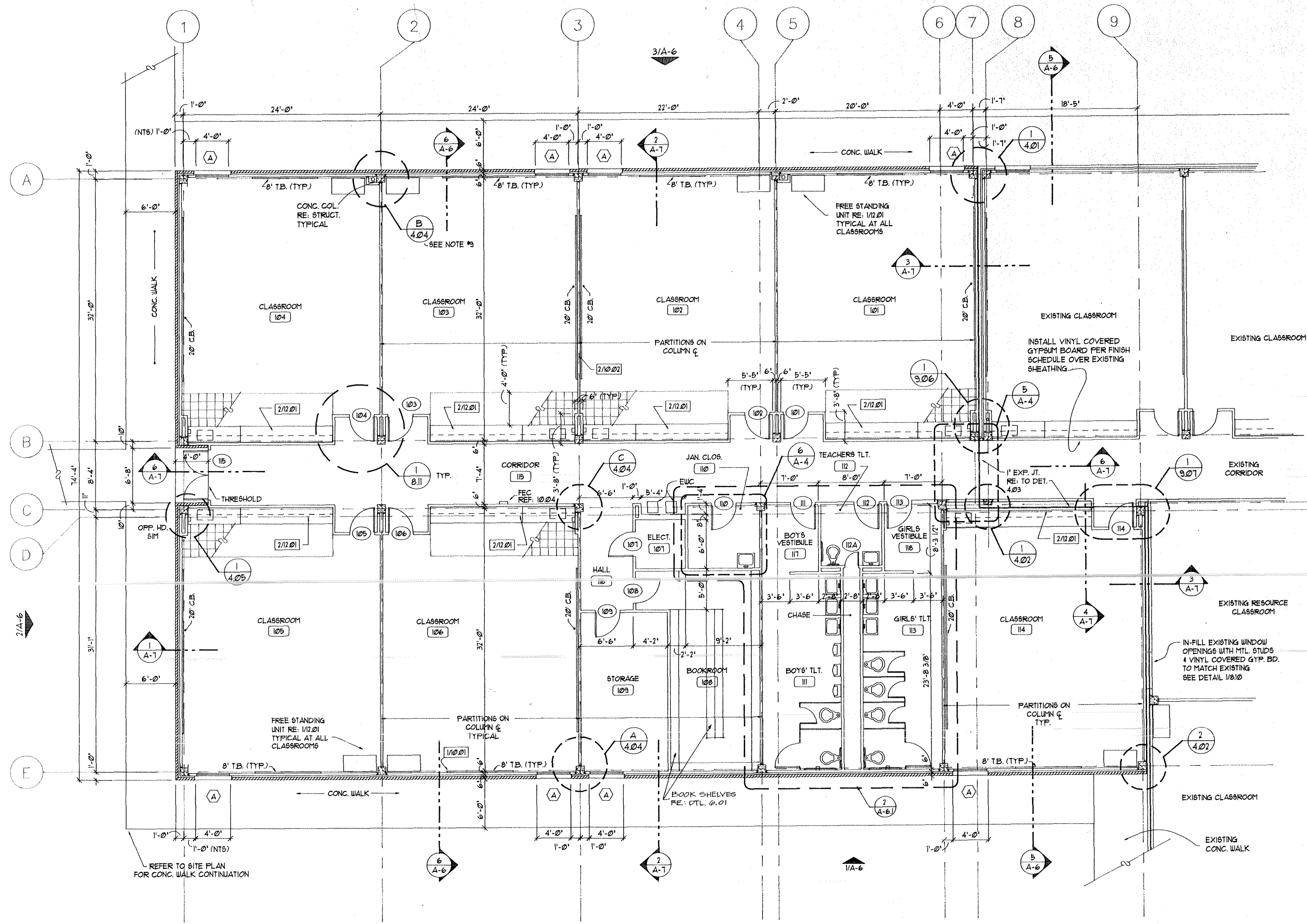

5 PARTIAL PLAN-DUNCAN ADDITION
1/8" = 1'-0"

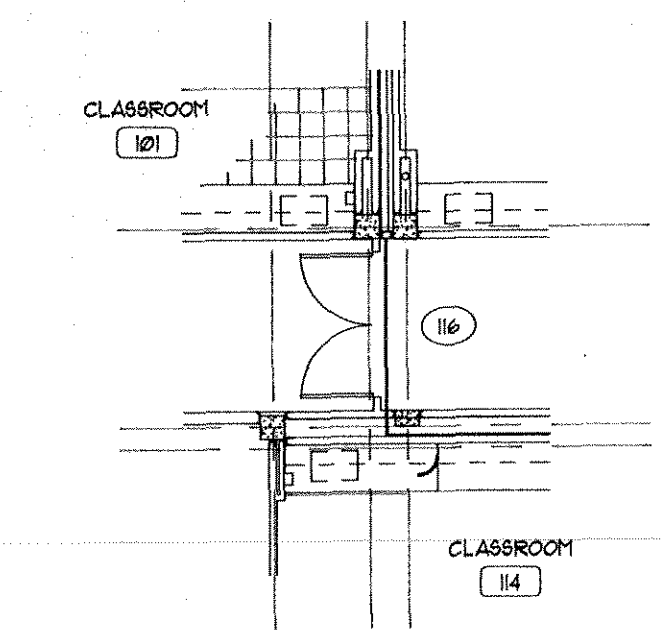

NOTE: AT THE DUNCAN ADDITION PROVIDE COMPARTMENTATION DOOR AS SCHEDULE 4 INDICATED ABOVE. PROVIDE 1 HOUR RATED CORRIDOR WALL ABOVE DOOR OPENING TO ROOF DECK.

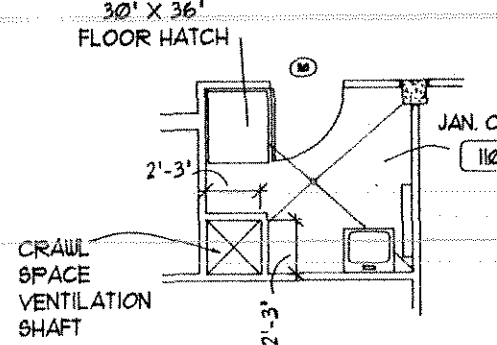

NOTE: AT HAY BRANCH ADDITION PROVIDE VENTILATION SHAFT & FLOOR HATCH INDICATED ABOVE. VENTILATION SHAFT WALLS TO BE INSULATED & EXTENDED TO ROOF DECK.

6 PARTIAL PLAN - HAYBRANCH ADDITION
1/8" = 1'-0"

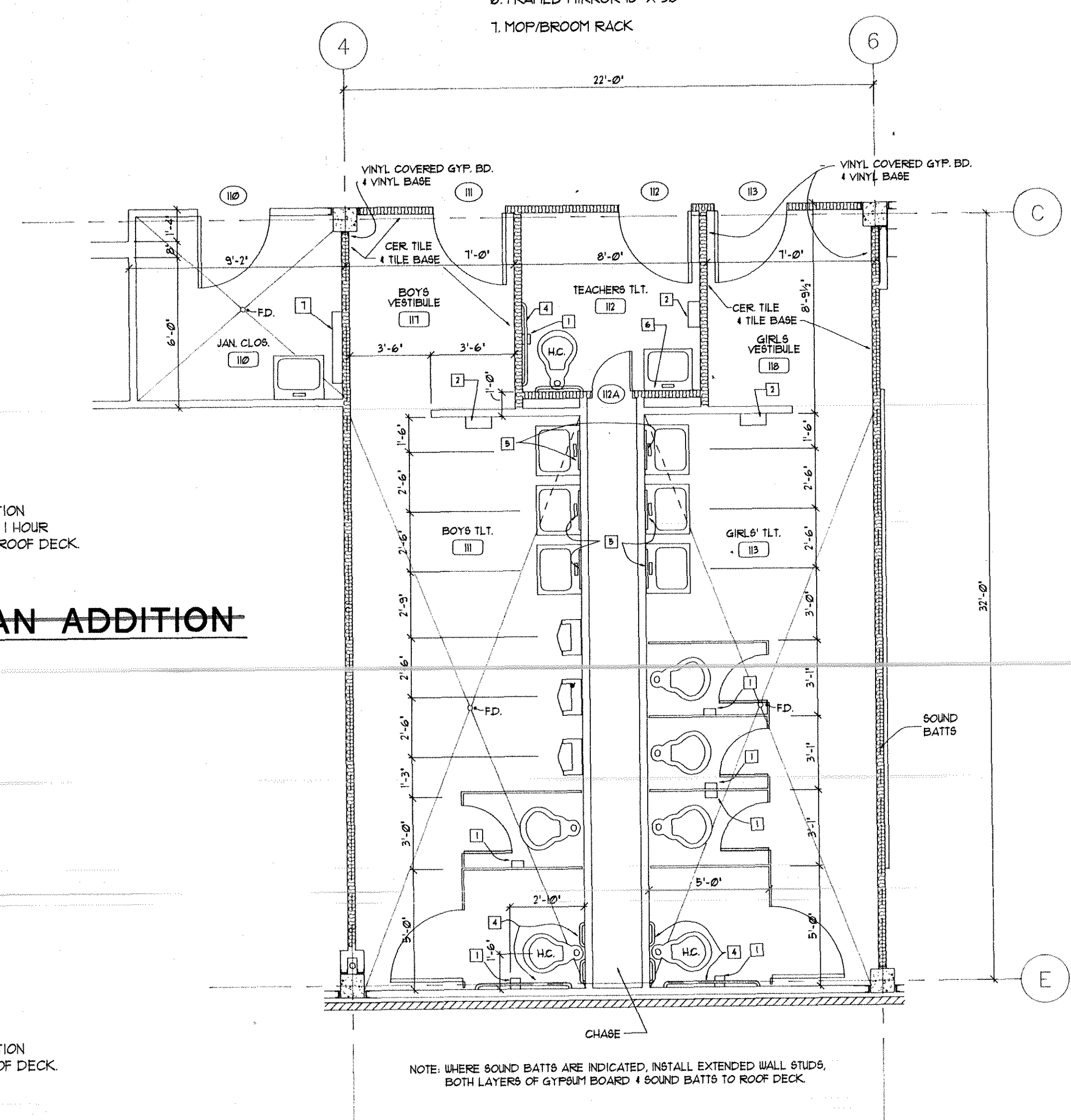

NOTE: WHERE SOUND BATTIS ARE INDICATED, INSTALL EXTENDED WALL STUDS, BOTH LAYERS OF GYP BOARD & SOUND BATTIS TO ROOF DECK.

- TOILET ACCESSORY LEGEND**
1. TOILET TISSUE DISPENSER
 2. PAPER TOWEL DISPENSER (PROVIDE ONE IN EA. CLASSRM-TYPICAL)
 3. NOT USED
 4. GRAB BARS, REFER TO PLAN FOR LENGTH
 5. FRAMED MIRROR 18" X 24"
 6. FRAMED MIRROR 18" X 36"
 7. MOP/BROOM RACK

1 FLOOR PLAN
1/8" = 1'-0"

PLAN NORTH
ALL ADDITIONS REFER TO SITE PLAN FOR EACH SCHOOL ADDITION FOR TRUE NORTH

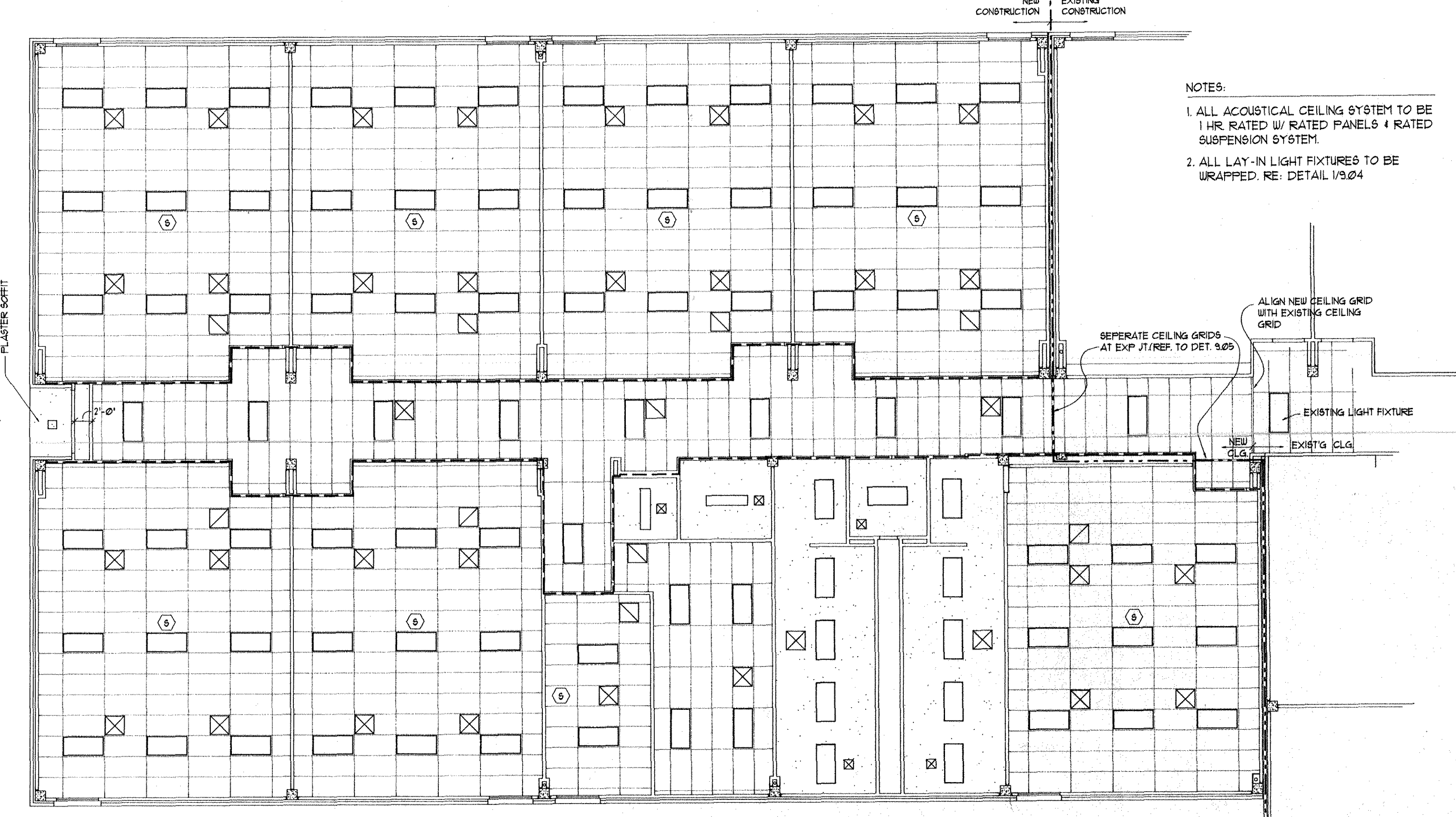

- NOTES:**
1. ALL ACOUSTICAL CEILING SYSTEM TO BE 1 HR. RATED W/ RATED PANELS & RATED SUSPENSION SYSTEM.
 2. ALL LAY-IN LIGHT FIXTURES TO BE UNWRAPPED. RE: DETAIL 1/5/04

- GENERAL NOTES:**
1. REFER TO DETAIL BOOK 10.06 FOR TYP. TOILET FIXTURE MOUNTING HEIGHTS.
 2. INSTALL ACCESS DOORS IN LOCATIONS INDICATED IN MECHANICAL SPECIFICATION.
 3. REFER TO 8.00 IN DETAIL BOOK FOR DOOR SCHEDULE.
 4. REFER TO 8.06 IN DETAIL BOOK FOR WINDOW TYPES.
 5. REFER TO 4.00 IN DETAIL BOOK FOR TYP. COLUMN PLAN DETAILS.
 6. REFER TO SECTION 9.00 IN DETAIL BOOK FOR FINISH SCHEDULE.
- REFLECTED CEILING PLAN LEGEND:**
- SUSPENDED 2' x 4' LAY-IN ACOUSTICAL TILE CEILING AS SCHEDULED
 - LAY-IN LIGHT FIXTURE - TYPICAL
 - SURFACE MOUNT OR PENDANT LIGHT FIXTURE
 - RECESSED LIGHT FIXTURE - TYPICAL
 - HVAC CEILING OUTLET LOCATION - TYPICAL
 - EXHAUST FAN OUTLET LOCATION - TYPICAL
 - EXTERIOR PLASTER OR INTERIOR GYP.BD. AS SCHEDULED
 - SPEAKER
- 1 HOUR RATED CORRIDOR WALL: 3 5/8" METAL STUD @ 16" O.C. TO ROOF DECK. 1 LAYER 5/8" TYPE "X" GYP.BD. BOARD EACH SIDE. FULL HEIGHT SEALED TO ROOF DECK - UL DESIGN #425. 1 HOUR. FINISH AS SCHEDULED.
- NON RATED WALL: 3 5/8" METAL STUD @ 16" O.C. TO 6' ABOVE CEILING. BRACE TO STRUCTURE. 1 LAYER 5/8" TYPE "X" GYP.BD. BOARD EACH SIDE TO 6' ABOVE CEILING. FINISH AS SCHEDULED.

3 REFLECTED CEILING PLAN
1/8" = 1'-0"

2 FLOOR PLAN - TLTS. 111, 112 & 113
1/4" = 1'-0"

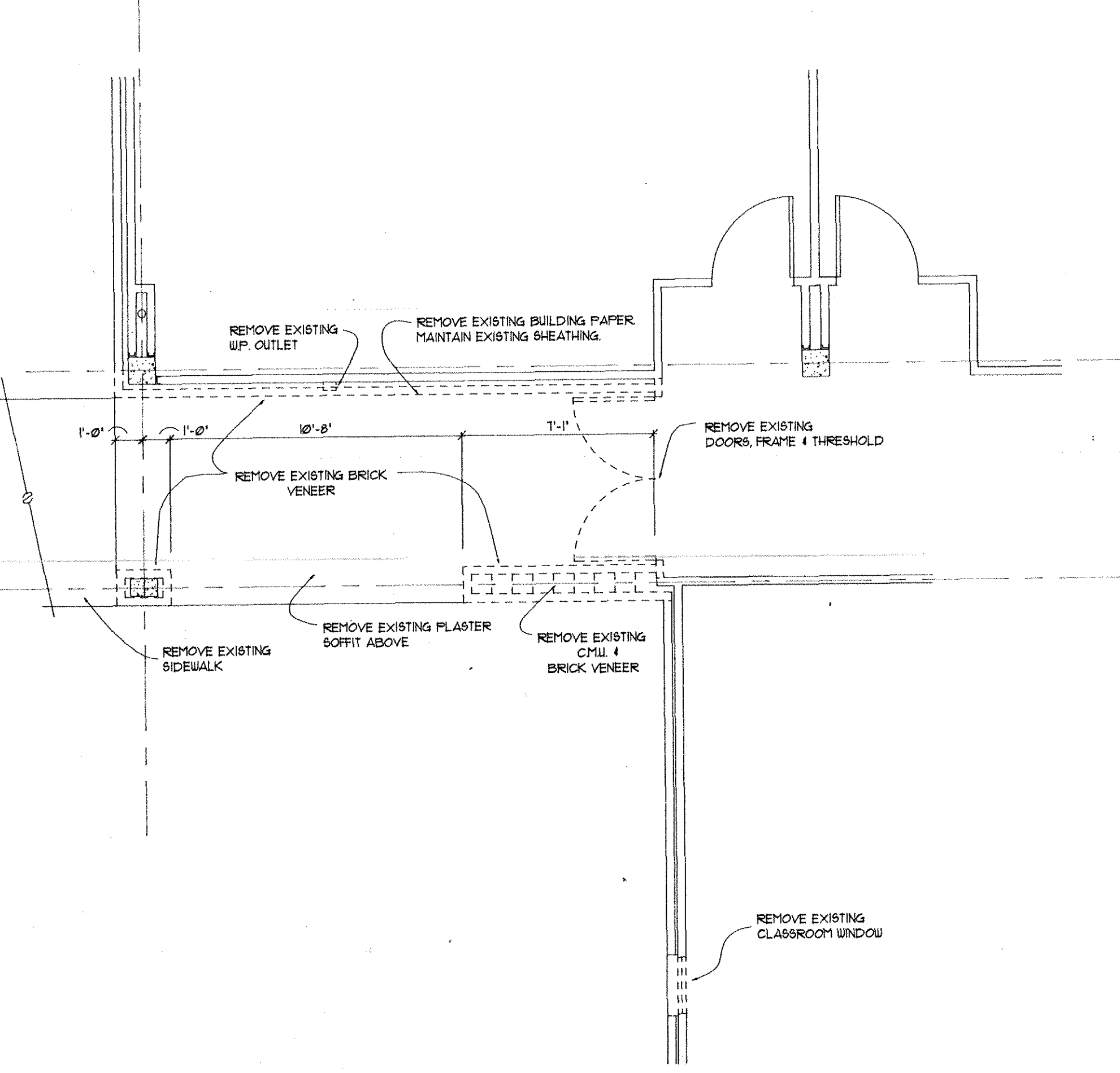

4 DEMOLITION PLAN
1/4" = 1'-0"

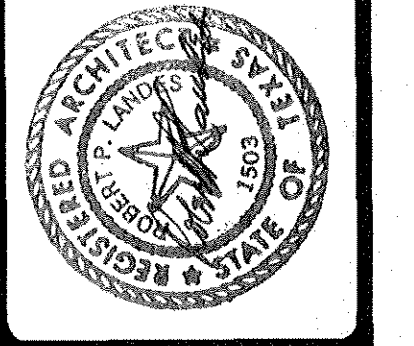

BLGY ARCHITECTS-ENGINEERS-PLANNERS 1600 W. 38TH STREET SUITE 100 JEFFERSON BUILDING AUSTIN, TX 78731 (512) 451-8281

FOUR ELEMENTARY SCHOOL ADDITIONS KILLEEN INDEPENDENT SCHOOL DISTRICT TEXAS

PROJECT NUMBER 9111 DATE 8 NOV. 91 SHEET A-4 OF 12

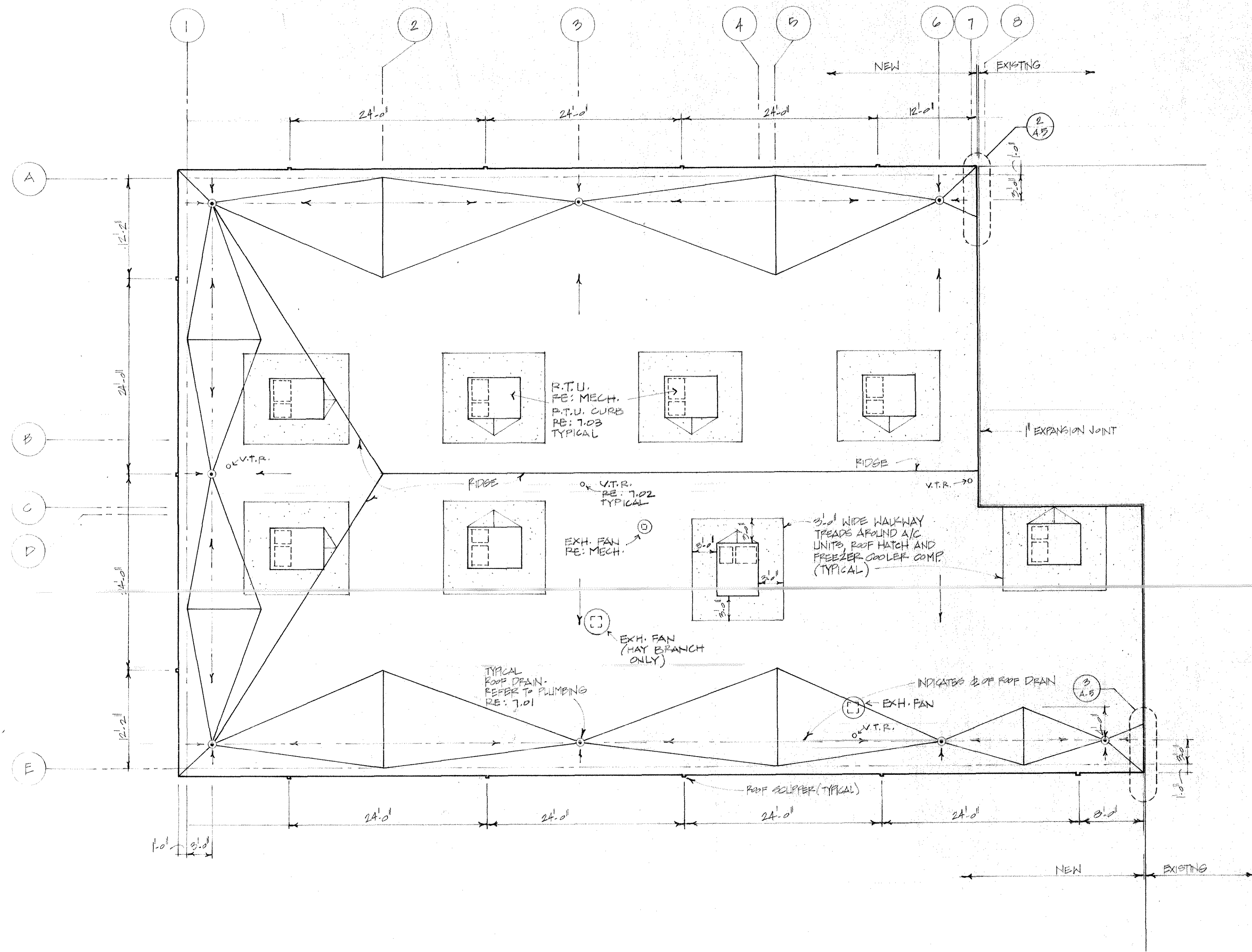

1 ROOF PLAN
1/8" = 1'-0"

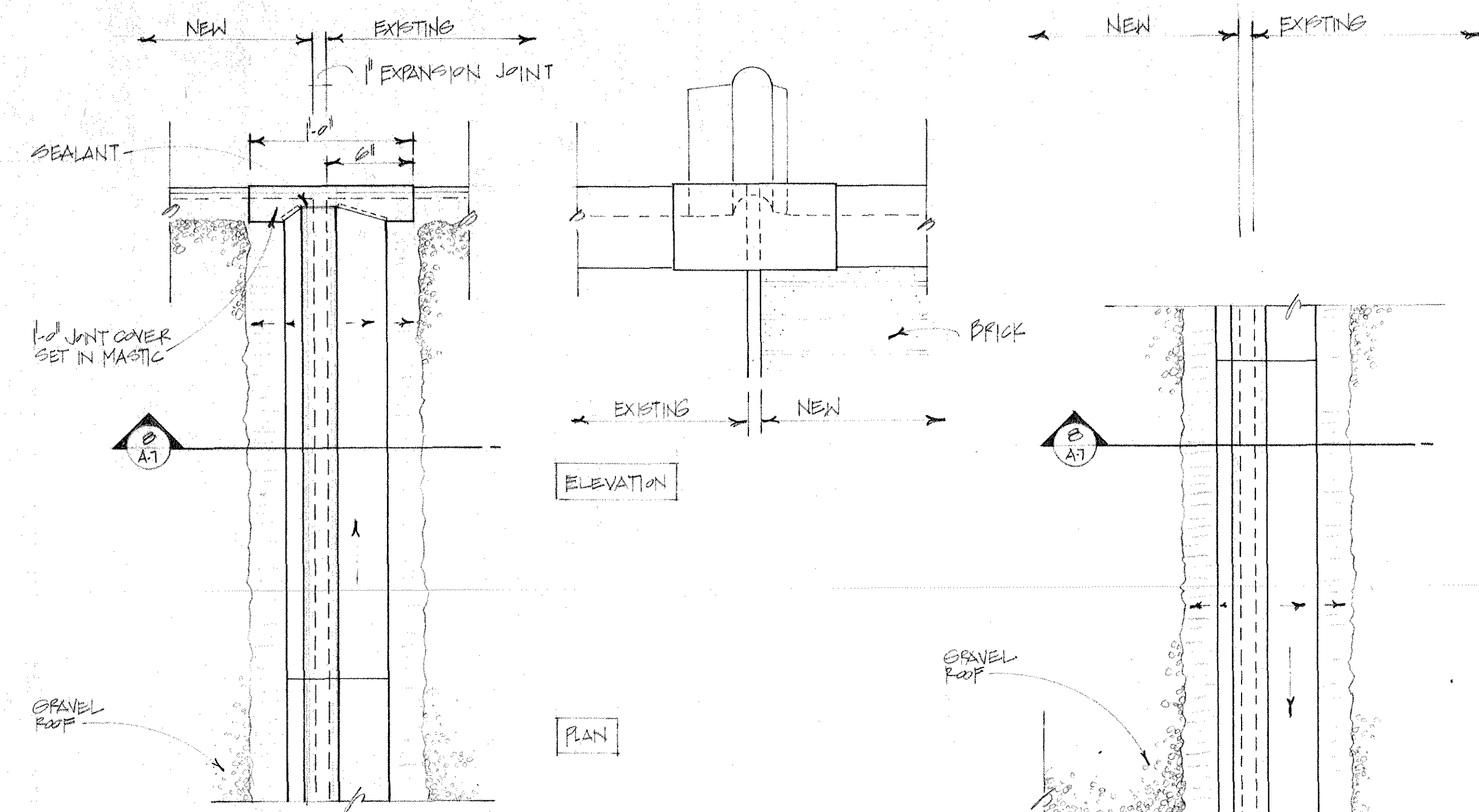

2 DETAILS
1 1/2" = 1'-0"

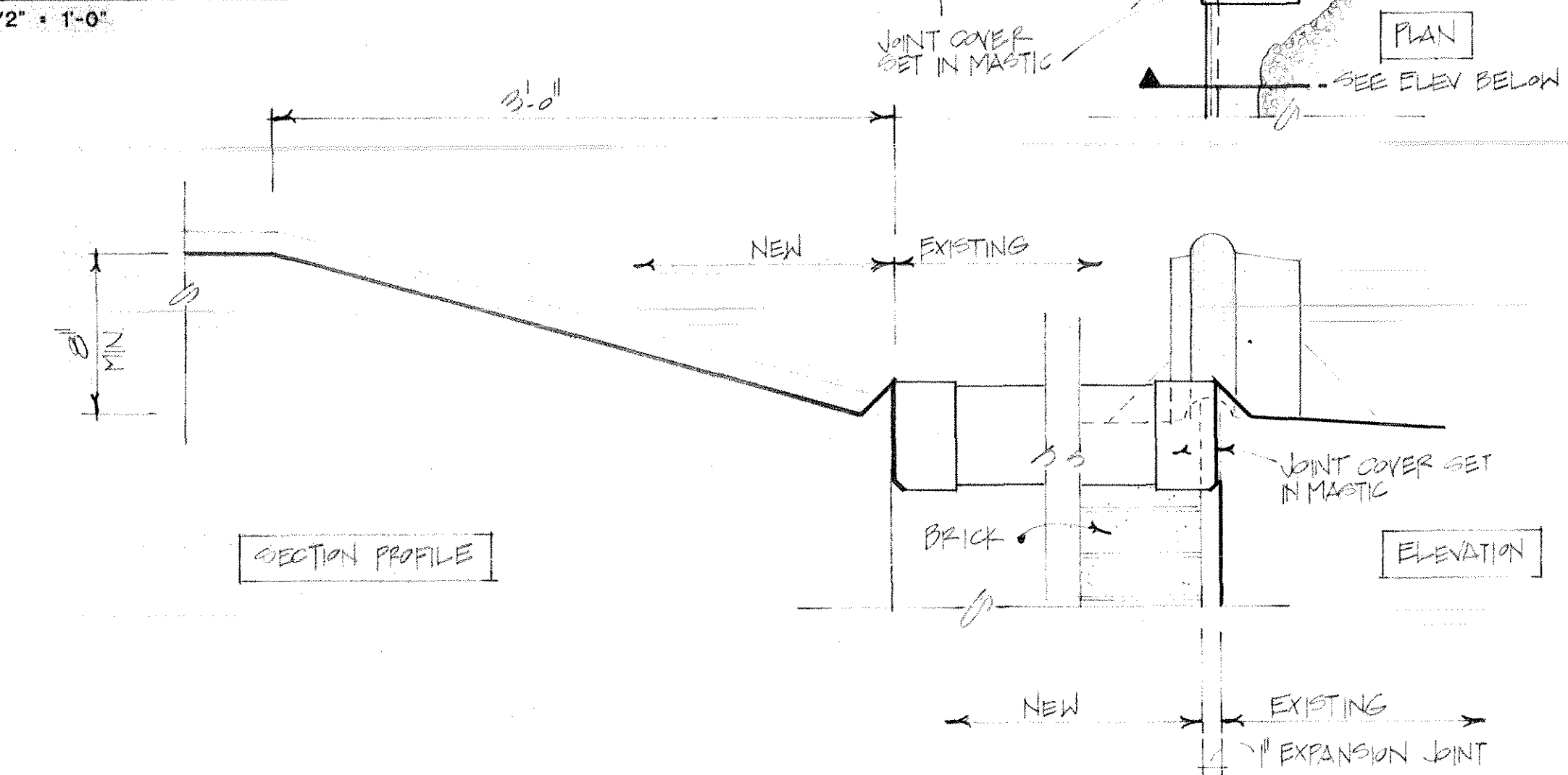

3 DETAILS
1 1/2" = 1'-0"

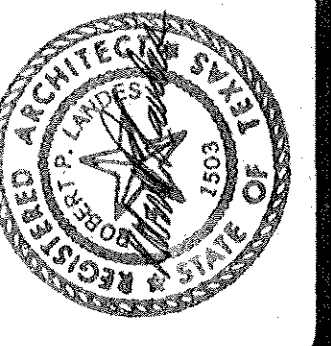

BLGY
INCORPORATED
ARCHITECTS-ENGINEERS-PLANNERS
1600 W. 38TH. STREET SUITE 100 JEFFERSON BUILDING AUSTIN, TX. 78731 (512) 451-8281

FOUR ELEMENTARY SCHOOL ADDITIONS
KILLEEN INDEPENDENT SCHOOL DISTRICT TEXAS

PROJECT NUMBER 211
DATE 8 Nov 91
SHEET A-5
OF 12

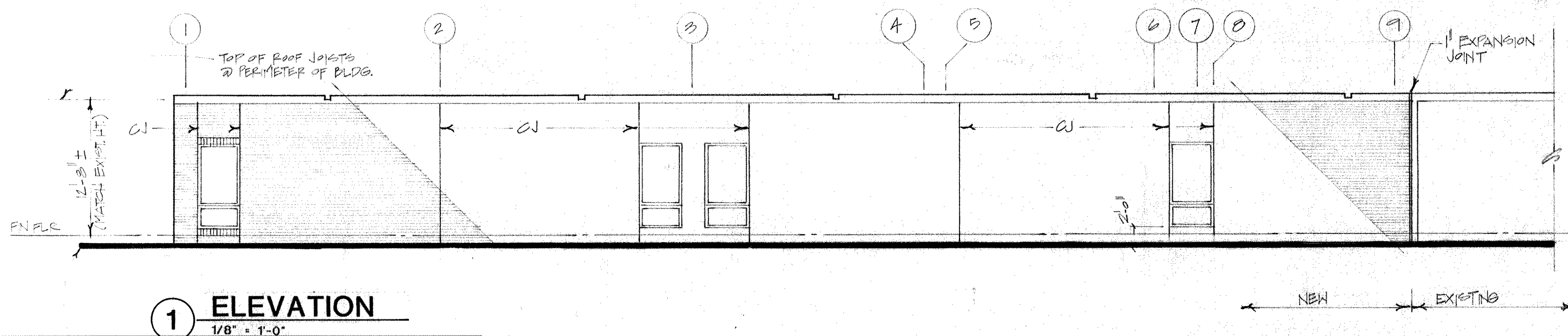

1 ELEVATION
1/8" = 1'-0"

LATEST FINISH GRADE - DUNCAN, WILLOW SPRINGS AND MOUNTAIN VIEW ADDITIONS.

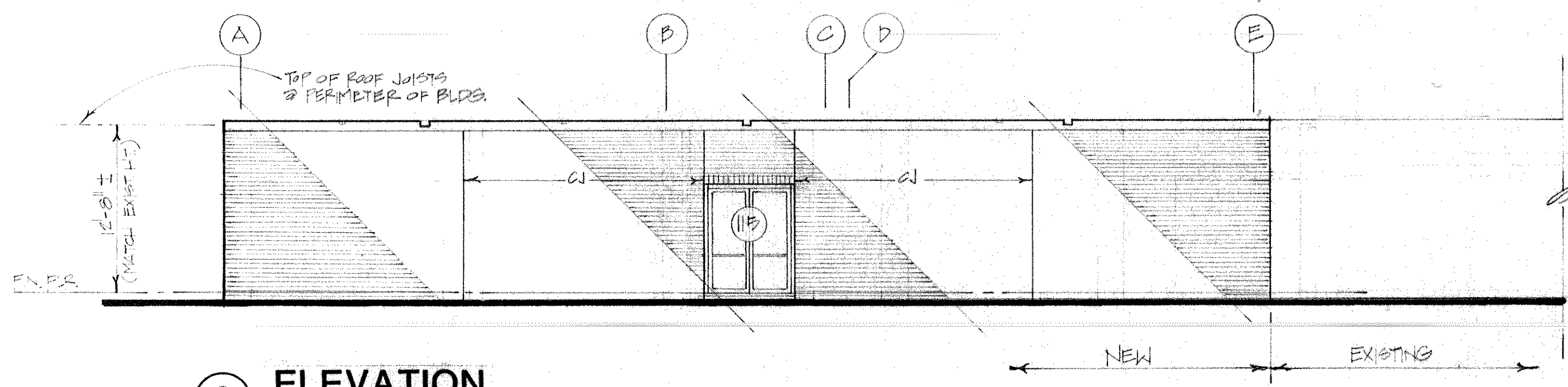

2 ELEVATION
1/8" = 1'-0"

NOTE: REFER TO FOUNDATION PLANS FOR PACE LEDGES ELEVATION.
COVER ALL EXTERIOR OPENINGS PROVIDE SLOTTED CURBS AT HEAD PROVIDE SLOPED FOULING COLLECTOR AT WINDOWS AND LOUVERS.

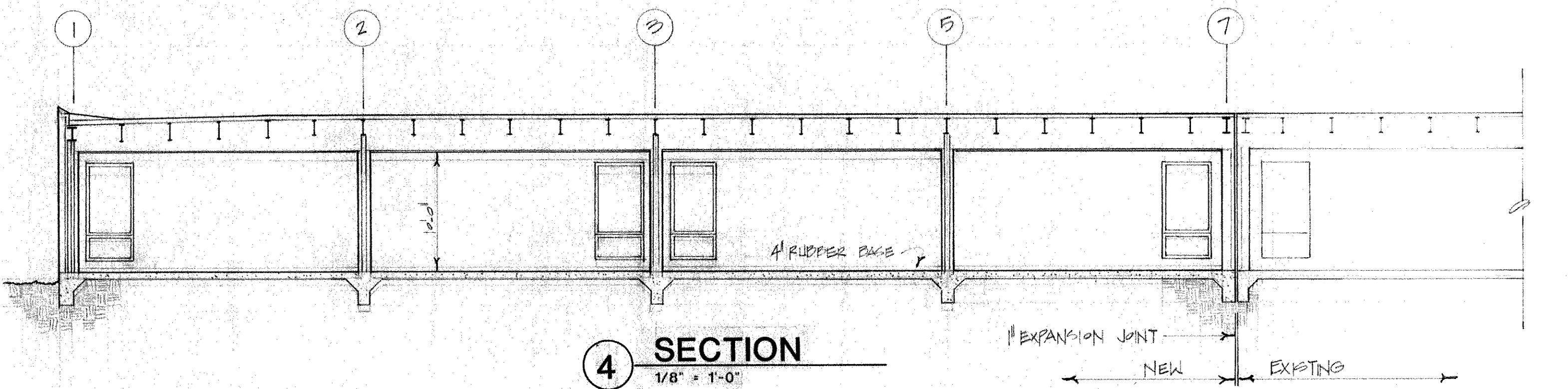

4 SECTION
1/8" = 1'-0"

NOTE: BUILDING SECTIONS INDICATE SLAB ON GRADE TYPICAL FOR ADDITIONS AT DUNCAN, WILLOW SPRINGS AND MOUNTAIN VIEW. HANDBRANCH ADDITION FOUNDATION OVER CRANK SPACE.

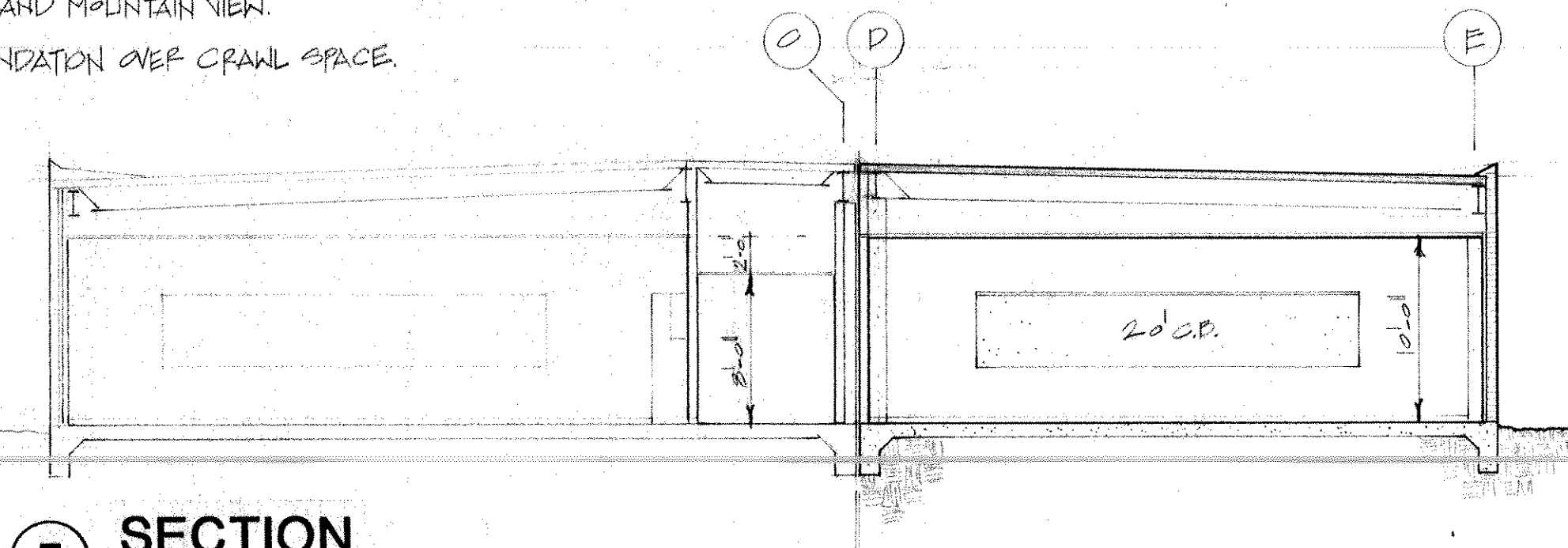

5 SECTION
1/8" = 1'-0"

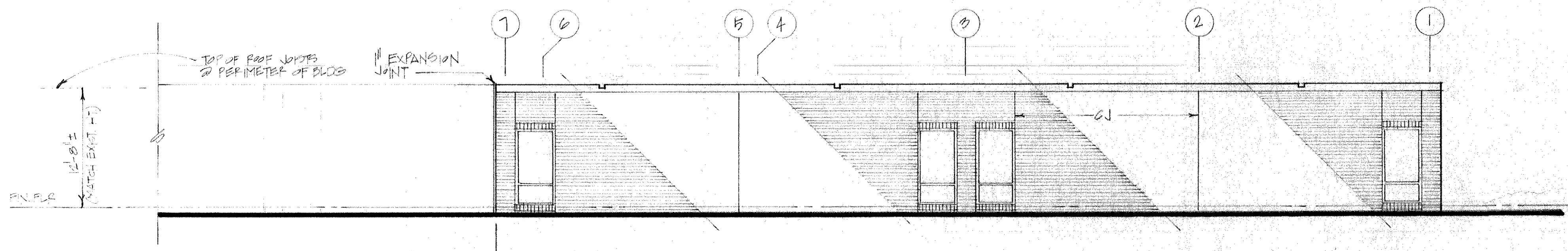

3 ELEVATION
1/8" = 1'-0"

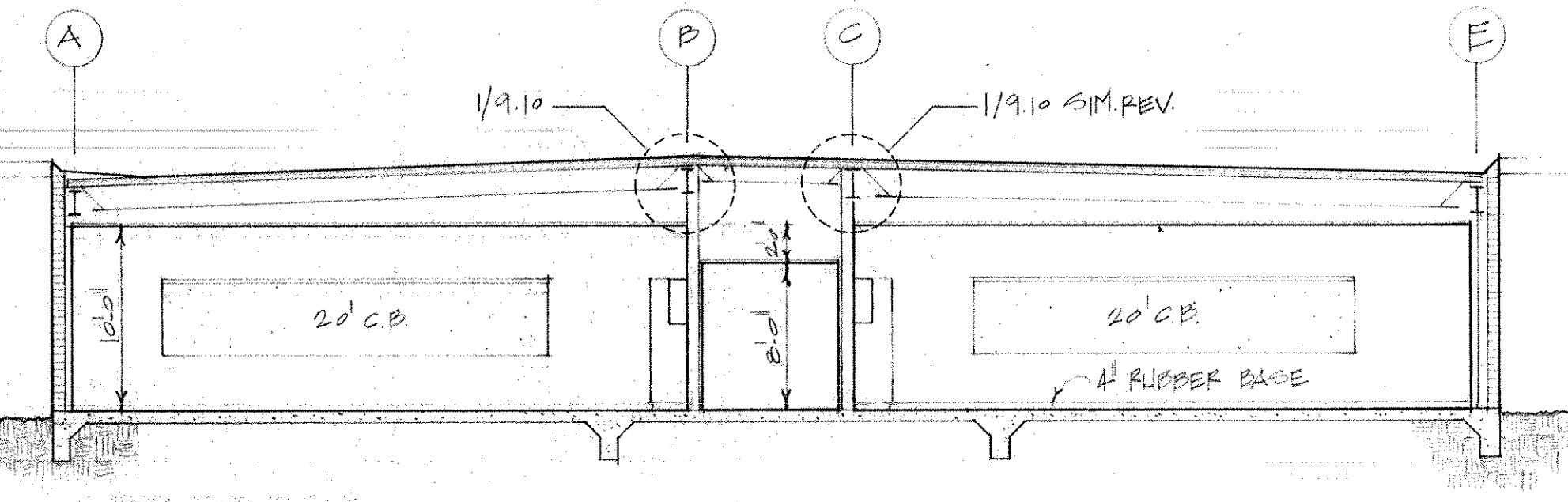

6 SECTION
1/8" = 1'-0"

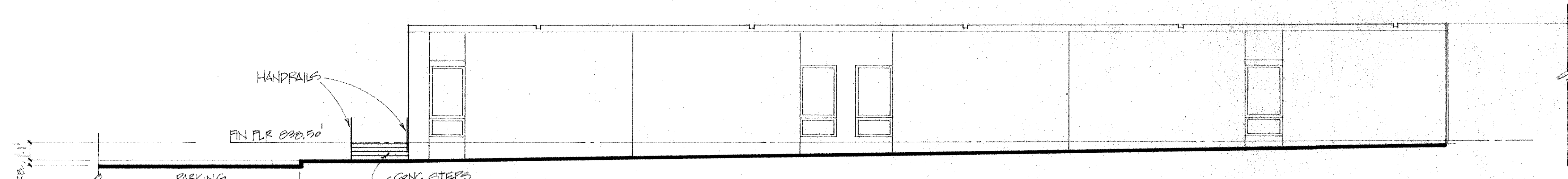

1A ELEVATION (HAY BRANCH ONLY)
1/8" = 1'-0"

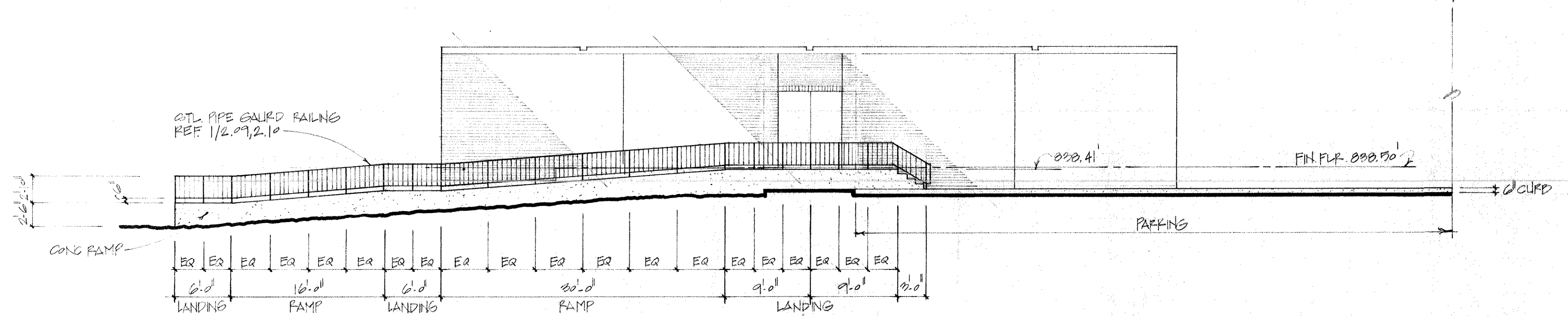

2A ELEVATION (HAY BRANCH ONLY)
1/8" = 1'-0"

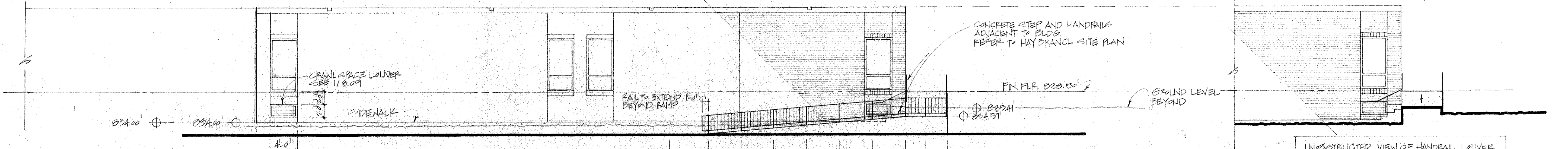

3A ELEVATION (HAY BRANCH ONLY)
1/8" = 1'-0"

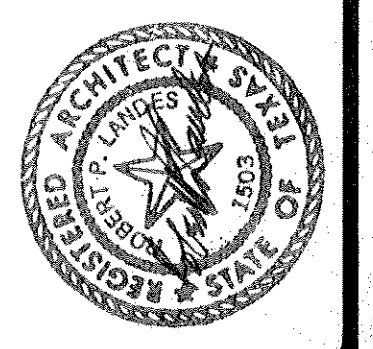

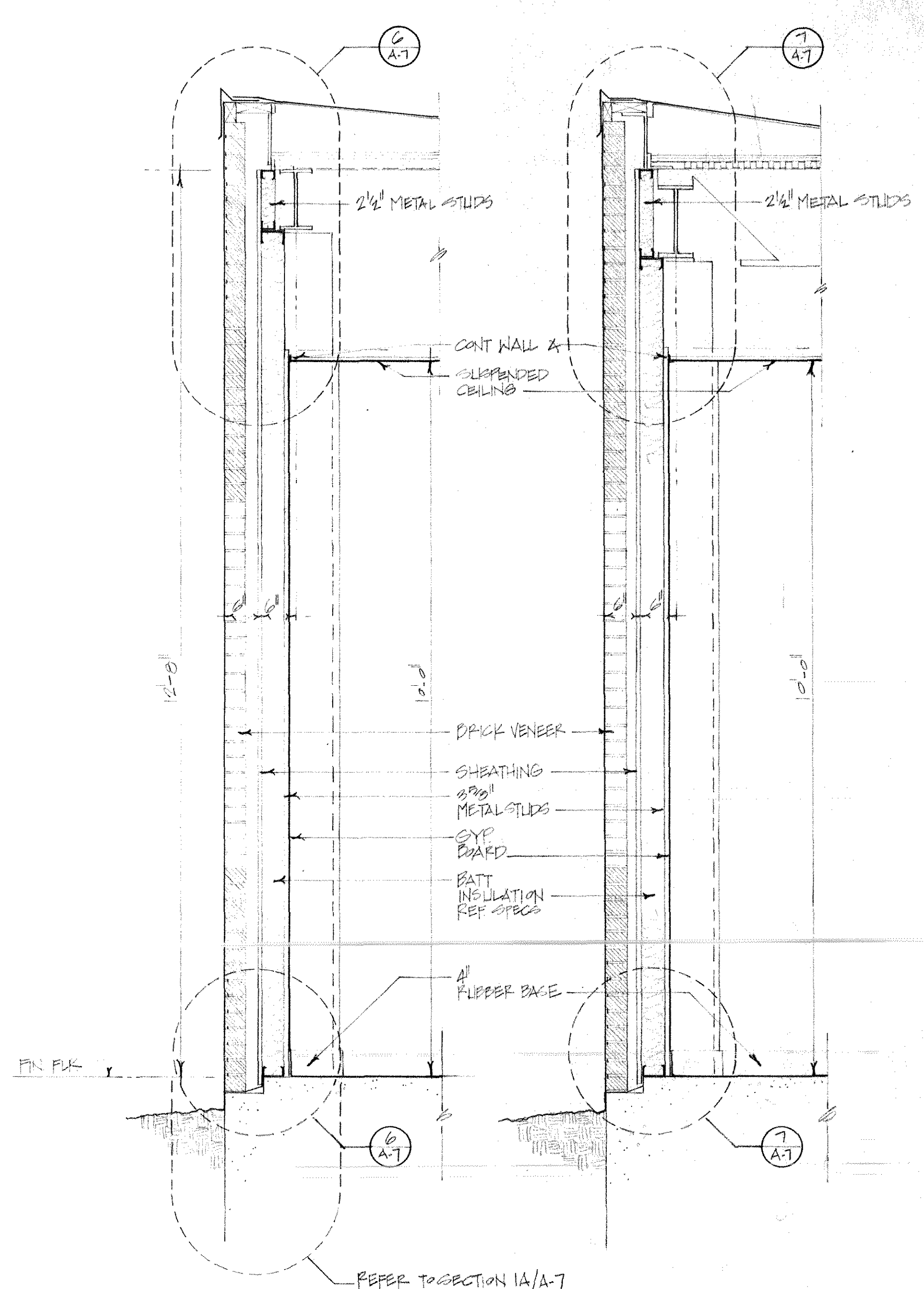
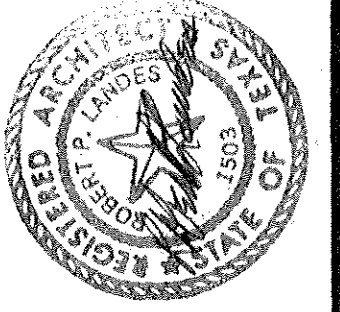

1 SECTION 3/4" = 1'-0"

2 SECTION 3/4" = 1'-0"

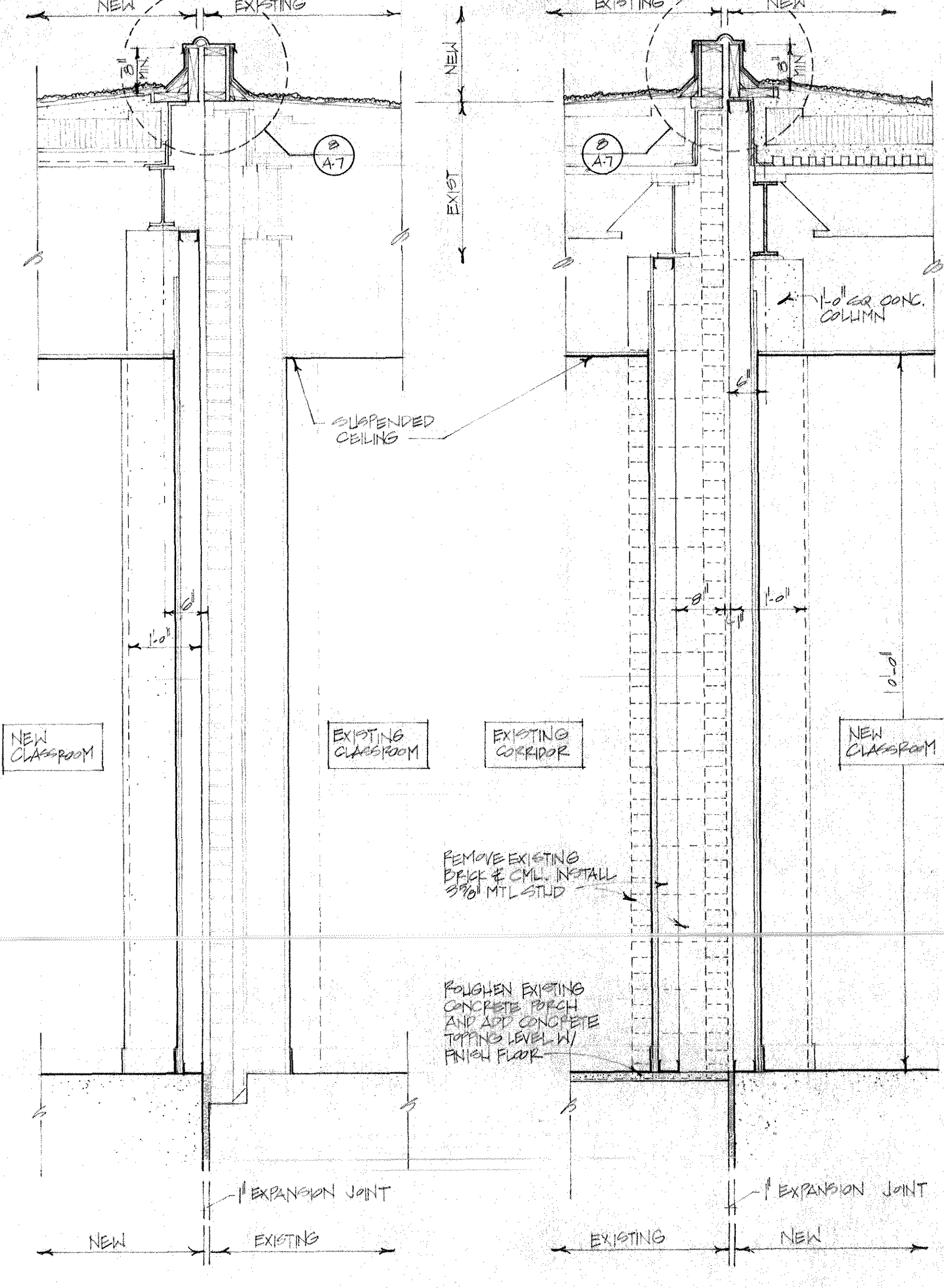

3 SECTION 3/4" = 1'-0"

4 SECTION 3/4" = 1'-0"

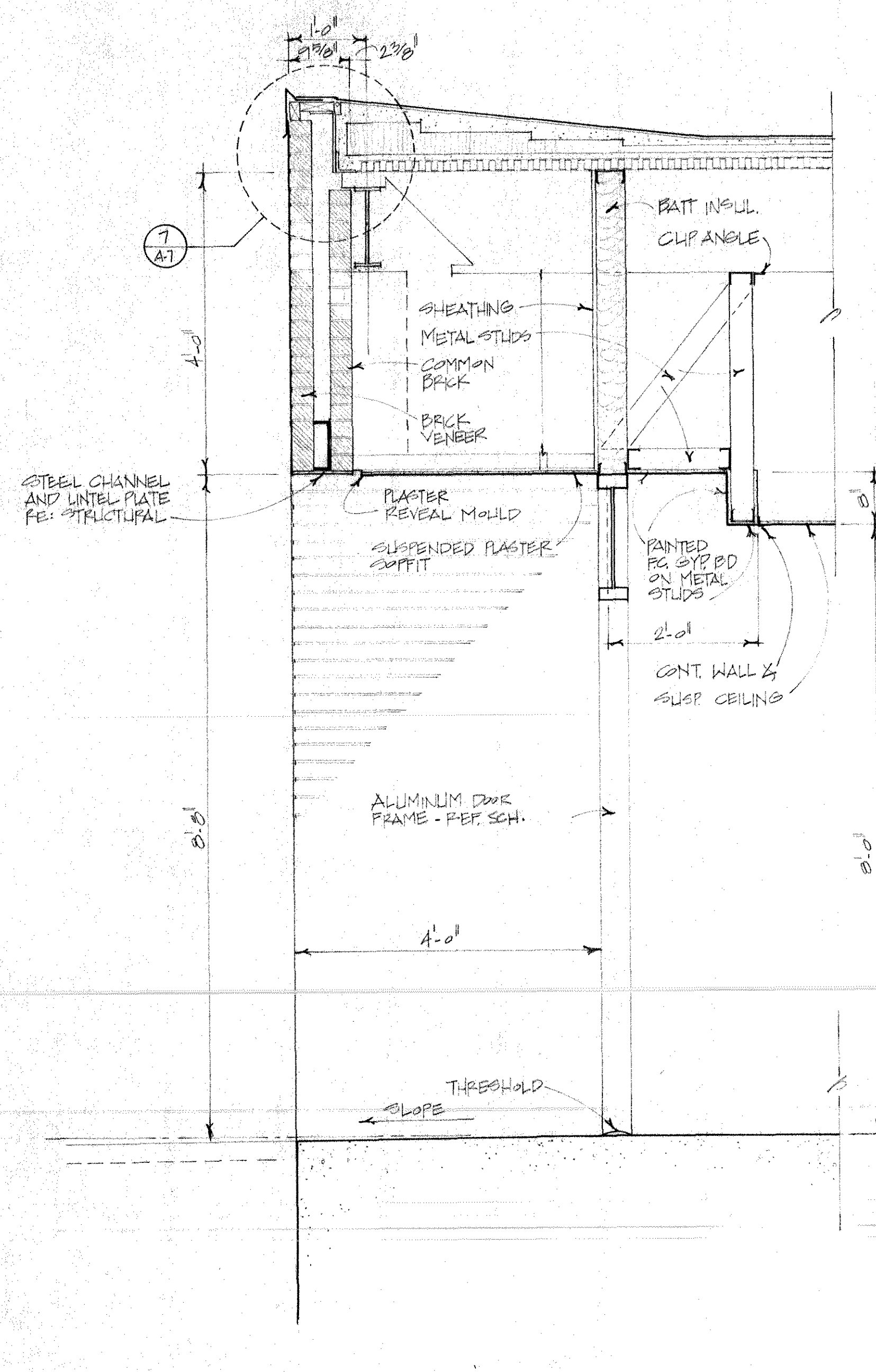

5 SECTION 3/4" = 1'-0"

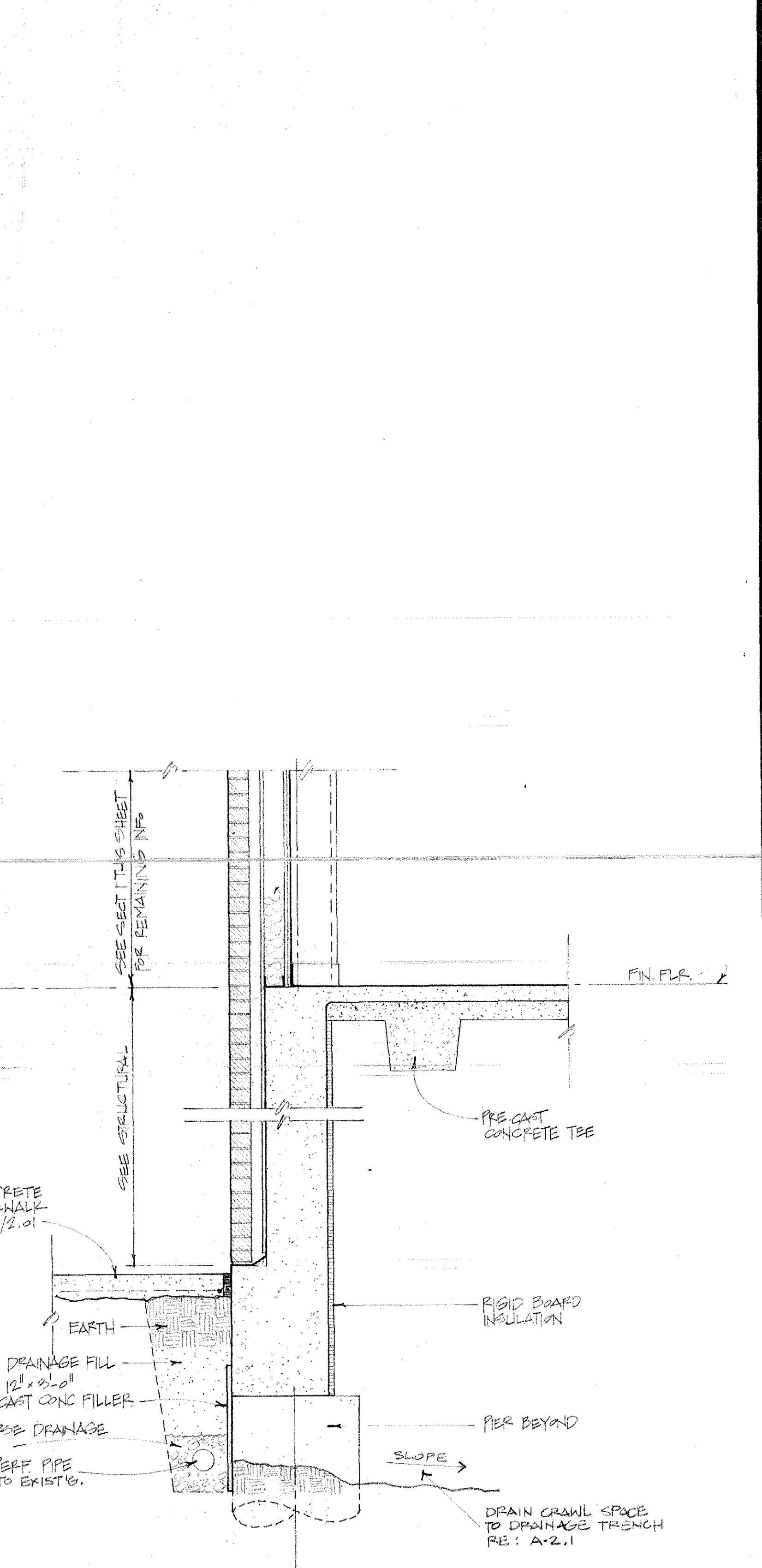

1A SECTION (HAY BRANCH ONLY) 3/4" = 1'-0"

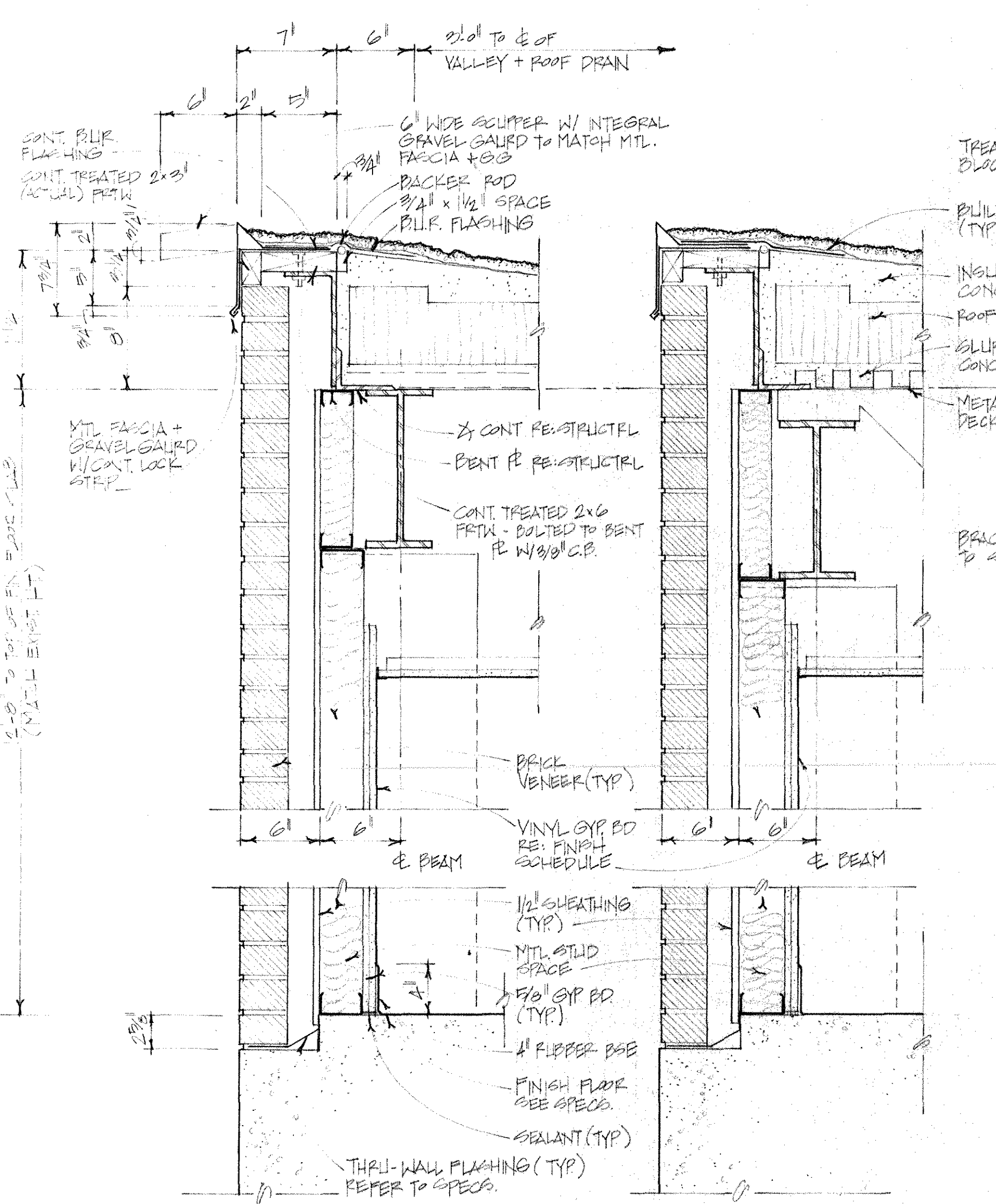

6 SECTION 1 1/2" = 1'-0"

7 SECTION 1 1/2" = 1'-0"

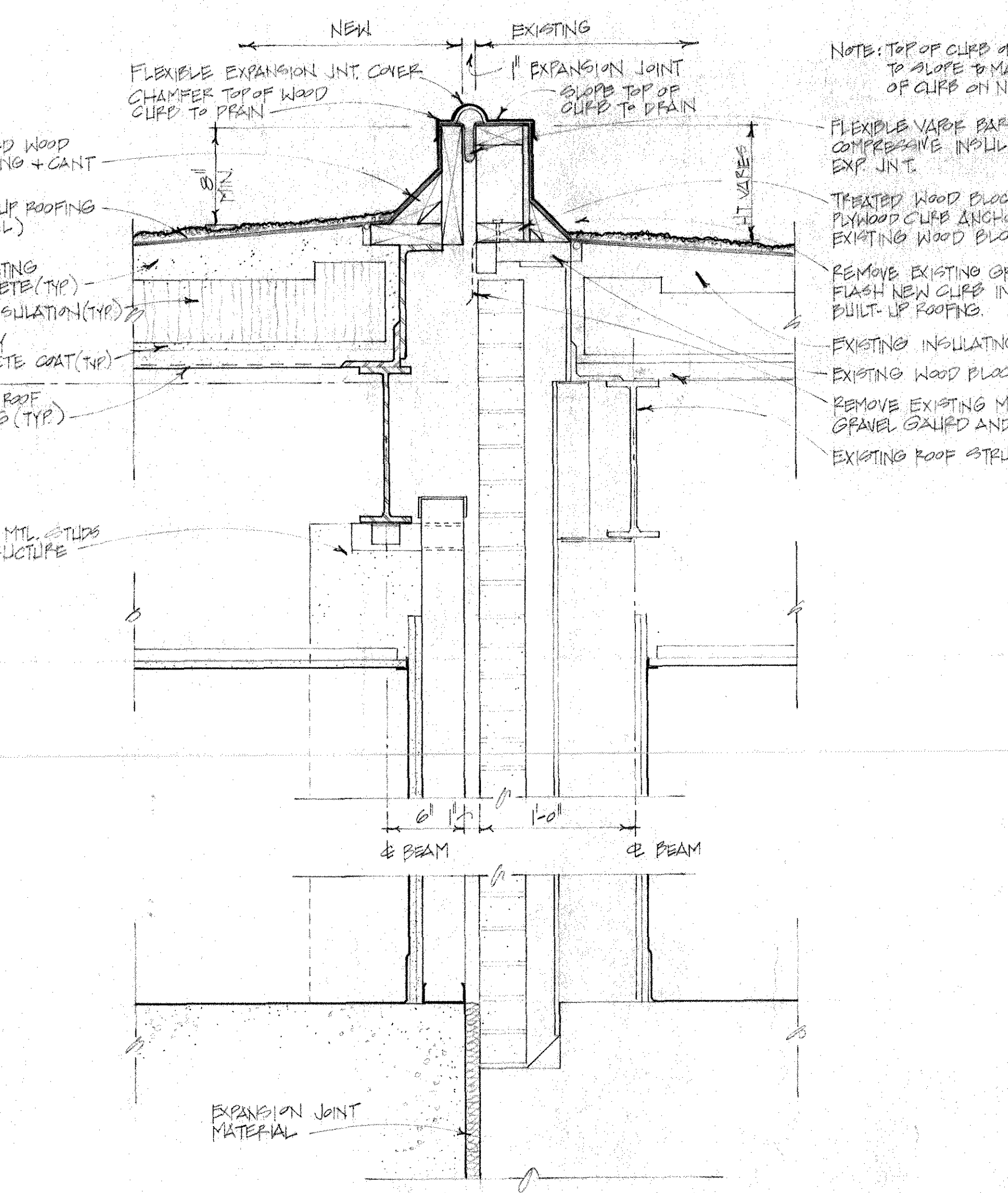

8 SECTION 1 1/2" = 1'-0"

NOTE: TOP OF CURB AT EXISTING ROOF TO SLOPE TO MATCH ELEVATION OF CURB ON NEW ROOF. FLEXIBLE VAPOR BARRIER FILLED W/ COMPRESSION INSUL. DRAFFED INTO EXP. JNT. TREATED WOOD BLOCKING AND PLYWOOD CURB ANCHOR BOLTED TO EXISTING WOOD BLOCKING. REMOVE EXISTING GRANUL AS REQ'D FLASH NEW CURB INTO EXISTING BUILT-UP ROOFING. EXISTING INSULATING CONCRETE. EXISTING WOOD BLOCKING. REMOVE EXISTING MTL FASCIA/GRANUL GALLED AND FLASHING. EXISTING ROOF STRUCTURE.

NOTE: NOTES + DIMENSIONS FOR THIS DETAIL ARE TYPICAL FOR ALL EDGE DETAILS UNLESS OTHERWISE INDICATED.

GENERAL NOTES

THESE GENERAL NOTES SHALL APPLY UNLESS OTHERWISE SPECIFICALLY NOTED ON PLANS AND DETAILS. THE CONTRACTOR SHALL VERIFY ALL DIMENSIONS AND SHALL COORDINATE ALL STRUCTURAL PLANS AND DETAILS WITH ARCHITECTURAL DRAWINGS BEFORE STARTING WORK. THE ENGINEER SHALL BE NOTIFIED OF ANY DISCREPANCIES PRIOR TO CONSTRUCTION. DESIGN, CONSTRUCTION, WORKMANSHIP AND MATERIALS SHALL COMPLY WITH THE LATEST EDITION OF THE UNIFORM BUILDING CODE.

DESIGN CRITERIA

- LIVE LOADS:
 - FLOOR 100 PSF
 - ROOF 20 PSF
- WIND LOAD 20 PSF
- FOUNDATION DESIGN IS BASED ON THE GEOTECHNICAL INVESTIGATION PREPARED BY: TRINITY ENGINEERING TESTING CORP. DATED:

FOUNDATION NOTES (REFER TO GEOTECHNICAL REPORT FOR LOG OF BORINGS)

- FOR A DISTANCE OF 3'-0" OUTSIDE THE BUILDING LINE, REMOVE ALL BROWN CLAY DOWN TO TOP OF TAN SEVERELY WEATHERED MARLY LIMESTONE, AND ANY ADDITIONAL AMOUNT OF ANY MATERIAL REQUIRED TO INSURE THAT FINAL GRADING WILL PROVIDE A MINIMUM OF 12" OF SELECT FILL BELOW THE BOTTOM OF THE FOUNDATION BEAMS.
- REWORK AND COMPACT THE TOP 6" OF THE EXPOSED SUBGRADE (EXCEPTING AT ROCK) TO 95% OF STANDARD PROCTOR DENSITY (ASTM D 698-78) AT A MOISTURE CONTENT ABOVE OPTIMUM.
- FILL BACK TO REQUIRED GRADE WITH EITHER CRUSHED LIMESTONE BASE OR SELECT GRANULAR FILL AS SPECIFIED BELOW.
- a) CRUSHED LIMESTONE BASE MATERIAL: STATE DEPARTMENT OF HIGHWAYS AND PUBLIC TRANSPORTATION (SDHPT) ITEM 248, TYPE A, GRADE 2 OR BETTER.
- b) SELECT, NON-EXPANSIVE GRANULAR FILL: THIS FILL SHALL BE A SELECT, NON-EXPANSIVE MATERIAL WITH SUFFICIENT SOIL BINDER TO ALLOW FOR PROPER COMPACTION. IT SHALL ALSO MEET THE FOLLOWING SPECIFICATION:

MAXIMUM AGGREGATE SIZE	3.0 INCHES
PERCENT RETAINED ON #4 SIEVE	25 - 50
PERCENT RETAINED ON #40 SIEVE	50 - 75
PLASTICITY INDEX	5 - 15
- SAMPLES OF PROPOSED SELECT FILL SHALL BE FURNISHED TO THE TESTING LABORATORY 7 DAYS PRIOR TO INSTALLATION TO PERMIT TIME FOR SPECIFICATION COMPLIANCE INSPECTION AND APPROVAL.
- SELECT FILL SHALL BE COMPACTED IN THE FIELD IN LIFTS NOT TO EXCEED 6" TO A MINIMUM OF 95% OF MAXIMUM DENSITY AS DETERMINED BY ASTM D-1557-78 (MODIFIED PROCTOR). FIELD DENSITIES SHALL BE CHECKED IN ACCORDANCE WITH ASTM D-2922.
- LABORATORY MOISTURE-DENSITY CURVE OR CURVES AS REQUIRED, AND RESULTS OF AT LEAST 3 FIELD DENSITY CHECKS PER LIFT SHALL BE SUBMITTED TO THE ARCHITECT OR ENGINEER.

CONCRETE

- ALL CONCRETE WORK SHALL CONFORM TO THE AMERICAN CONCRETE INSTITUTE SPECIFICATION, A.C.I. #301 AND BUILDING CODE REQUIREMENTS, A.C.I. #318, LATEST EDITION.
- ALL DETAILING, FABRICATION AND ERECTION OF REINFORCING BARS, UNLESS OTHERWISE NOTED, MUST FOLLOW THE A.C.I. "MANUAL OF STANDARD PRACTICE FOR DETAILING REINFORCED CONCRETE", A.C.I. #315, LATEST EDITION.
- CONCRETE SHALL HAVE A MINIMUM COMPRESSION STRENGTH AT 28 DAYS AS FOLLOWS:

3,000 PSI FOR ALL CONCRETE

BUT NOT LESS THAN 5 SACKS OF CEMENT SHALL BE USED PER CUBIC YARD OF CONCRETE REGARDLESS OF STRENGTHS OBTAINED, NOT OVER 7-1/2 GALLONS OF WATER PER SACK OF CEMENT AND NOT OVER 5 INCH SLUMP. FURNISH MIX DESIGN FOR ALL CLASSES OF CONCRETE. RETAIN A QUALIFIED TESTING LABORATORY TO MAKE CONCRETE CYLINDERS AND PERFORM COMPRESSIVE TESTS. A MINIMUM OF THREE CYLINDERS SHALL BE TAKEN PER 50 CUBIC YARDS OF CONCRETE, WITH ONE TEST AT 7 DAYS AND TWO AT 28 DAYS.

- REINFORCING BARS SHALL BE NEW BILLET STEEL CONFORMING TO ASTM A-615, GRADE 60.
- STANDARD PROTECTIVE COVER OF REINFORCING BARS UNLESS OTHERWISE NOTED SHALL BE:

WHERE CAST AGAINST DIRT OR FILL	3 IN.
EXPOSED TO EARTH OR WEATHER	2 IN.
SLABS AND WALLS	1 IN.
OTHER	1-1/2 IN.

- AT CORNERS AND "T" INTERSECTIONS OF ALL BEAMS EXTEND 4 CORNER BARS EQUAL TO THE SCHEDULED STEEL IN THE ADJACENT BEAMS 2'-8" EACH WAY, 2 BARS TOP AND 2 BARS BOTTOM. MAKE ALL HORIZONTAL WALL STEEL CONTINUOUS AROUND CORNERS.
- ALL ACCESSORIES SHALL BE IN ACCORDANCE WITH THE A.C.I. "MANUAL OF STANDARD PRACTICE FOR DETAILING REINFORCED CONCRETE", A.C.I. #315, LATEST EDITION.
- VERTICAL CONSTRUCTION JOINTS IN FLOOR OR ROOF SLABS ARE TO BE AS SHOWN ON PLANS. NO HORIZONTAL JOINTS WILL BE PERMITTED IN SLABS OR BEAMS UNLESS OTHERWISE NOTED.
- ALLOW 1/2 TON OF REINFORCING BARS (ANY SIZE) TO BE USED AS DIRECTED IN FIELD FOR SPECIAL CONDITIONS (LABOR FOR PLACING SAME TO BE INCLUDED).
- MAINTAIN A MINIMUM OF ONE BAR DIAMETER (BUT NOT LESS THAN 1") BETWEEN ALL REINFORCING BARS (INCLUDING LAPS) ON ALL SLABS. MAINTAIN A MINIMUM OF 1-1/2" BETWEEN BARS IN COLUMNS, AND A MINIMUM OF 1-1/2 TIMES THE MAXIMUM COARSE AGGREGATE SIZE IN ALL CASES.

- BARS SCHEDULED AND DETAILED "CONT" SHALL BE LAPPED 24 BAR DIAMETERS UNLESS OTHERWISE NOTED.
- CONCRETE PLACED BY PUMPING SHALL MEET THE FOLLOWING REQUIREMENTS:
 - COARSE AGGREGATE SHALL BE GRADED FROM A MAXIMUM OF 1" DOWN.
 - MAXIMUM ALLOWABLE INCREASE IN CEMENT FACTOR SHALL BE 1/2 SACK PER CUBIC YARD OVER NORMAL MIX DESIGN.
 - MAXIMUM WATER CEMENT RATIO SHALL BE 7-1/2 GALLONS PER SACK OF CEMENT. IF MORE WORKABILITY IS REQUIRED, AN ADMIXTURE MAY BE USED.
 - MAXIMUM WEIGHT RATIO OF FINE AGGREGATES TO COARSE AGGREGATES SHALL NOT EXCEED 2/3.
 - REFER TO A.C.I. #301, LATEST EDITION, SECTION 800, FOR OTHER PUMPING REQUIREMENTS.
 - IN NO CASE SHALL CONCRETE BE PUMPED THROUGH AN ALUMINUM TUBE.
- SHOP DRAWINGS SHALL BE PREPARED FOR ALL REINFORCING STEEL AND SUBMITTED FOR REVIEW BY ENGINEER. ENGINEERING DRAWINGS SHALL NOT BE REPRODUCED AND USED AS SHOP DRAWINGS.
- LINTELS OVER OPENINGS IN NON-LOAD BEARING CMU WALLS NOT OTHERWISE NOTED SHALL BE OF STANDARD CMU LINTEL BLOCK WITH THICKNESS EQUAL TO WALL THICKNESS. DEPTH SHALL BE 8" FOR OPENINGS UP TO 6'-0", REINFORCED WITH TWO #5'S, BOTTOM. FOR OPENINGS BETWEEN 6'-0" & 12'-0", USE 16" DEEP CMU LINTEL WITH TWO #5'S, BOTTOM.
- WELDING OF REINFORCING BARS SHALL NOT BE PERMITTED, UNLESS APPROVED BY ENGINEER.

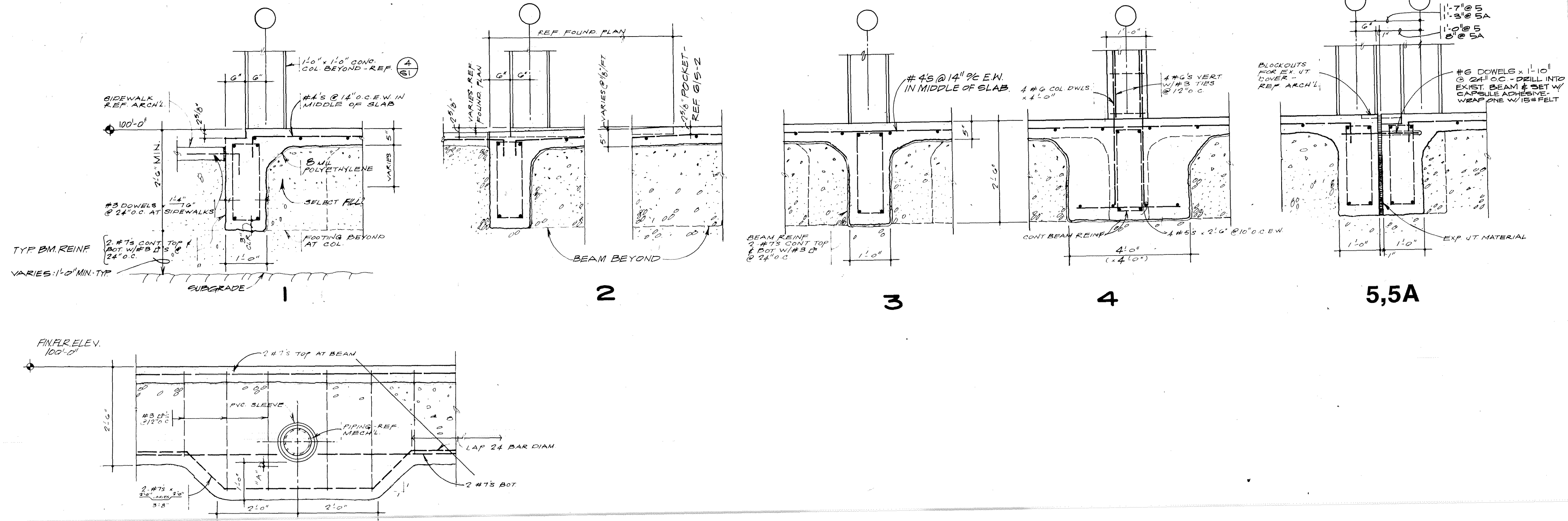

FOUNDATION DETAILS

- STRUCTURAL STEEL**
- ALL STRUCTURAL STEEL SHALL CONFORM TO THE ASTM SPECIFICATION A-36 UNLESS OTHERWISE SHOWN OR NOTED.
 - ALL STRUCTURAL STEEL TUBING SHALL CONFORM TO ASTM SPECIFICATION A-500, GRADE B.
 - ALL STRUCTURAL STEEL SHALL BE SPECIFIED, FABRICATED AND ERECTED IN ACCORDANCE WITH THE LATEST SPECIFICATIONS OF THE AMERICAN INSTITUTE OF STEEL CONSTRUCTION AND THE STEEL JOIST INSTITUTE.
 - ALL STRUCTURAL BOLTS SHALL CONFORM TO ASTM A-325 UNLESS OTHERWISE SHOWN OR NOTED. FURNISH HARDENED WASHERS AT ALL BOLTED CONNECTIONS, INCLUDING ANCHOR BOLTS.
 - REFER TO ARCHITECTURAL AND MECHANICAL PLANS FOR VERIFICATION OF ALL BOLTS, BLOCKING ANCHORS, ETC., FOR THE ANCHORAGE OF THEIR RESPECTIVE ITEMS.
 - ALL BEAMS AND COLUMNS SHALL BE FULL LENGTH WITHOUT SPLICES UNLESS OTHERWISE INDICATED ON PLANS.
 - ALL SHOP AND FIELD WELDS SHALL BE MADE BY WELDERS WHO HAVE BEEN QUALIFIED AND CERTIFIED TO MAKE THE REQUIRED WELDS WITHIN THE PREVIOUS SIX MONTHS IN ACCORDANCE WITH THE LATEST AMERICAN WELDING SOCIETY SPECIFICATIONS (A.W.S. D-1.1).
 - LINTELS OVER OPENINGS IN EXTERIOR WALLS UP TO 12'-0", NOT OTHERWISE COVERED SHALL BE ONE 5 x 3-1/2 x 5/16 ANGLE FOR EACH 4" OF MASONRY.
 - ERECTION CONNECTORS SHALL BE PROVIDED IN ORDER TO PROPERLY ALIGN AND BE TRUE AND PLUMB WHEN WELDS ARE MADE.
 - SHOP DRAWINGS SHALL BE PREPARED FOR ALL STRUCTURAL STEEL AND SUBMITTED FOR REVIEW BY ENGINEER. ENGINEERING DRAWINGS SHALL NOT BE REPRODUCED AND USED AS SHOP DRAWINGS.
 - ALL COMPLETE PENETRATION WELDS, BOTH SHOP AND FIELD, SHALL BE MADE UNDER THE OBSERVATION OF A QUALIFIED TESTING LABORATORY INSPECTOR.
 - THE FABRICATOR SHALL SUPPLY BACK UP PLATES AND EXTENSION TABS FOR ALL COMPLETE PENETRATION WELDS.
 - ALL COMPLETE PENETRATION WELDS SHALL BE X-RAYED BY A QUALIFIED TESTING LABORATORY. ANY WELDS FOUND DEFECTIVE SHALL BE REMOVED AND REPLACED AT NO ADDITIONAL COST TO THE OWNER.
 - ALL WELDS TO BE X-RAYED SHALL BE GROUND SMOOTH.
 - ALLOW 1/2 TON OF STRUCTURAL STEEL TO BE USED AS DIRECTED IN THE FIELD FOR SPECIAL CONDITIONS NOT COVERED BY NOTE OR DRAWING. (LABOR FOR ERECTING SAME TO BE INCLUDED.)
 - JOIST MANUFACTURER SHALL PROVIDE BRIDGING AS REQUIRED TO ADEQUATELY BRACE JOISTS AGAINST LATERAL MOVEMENT.

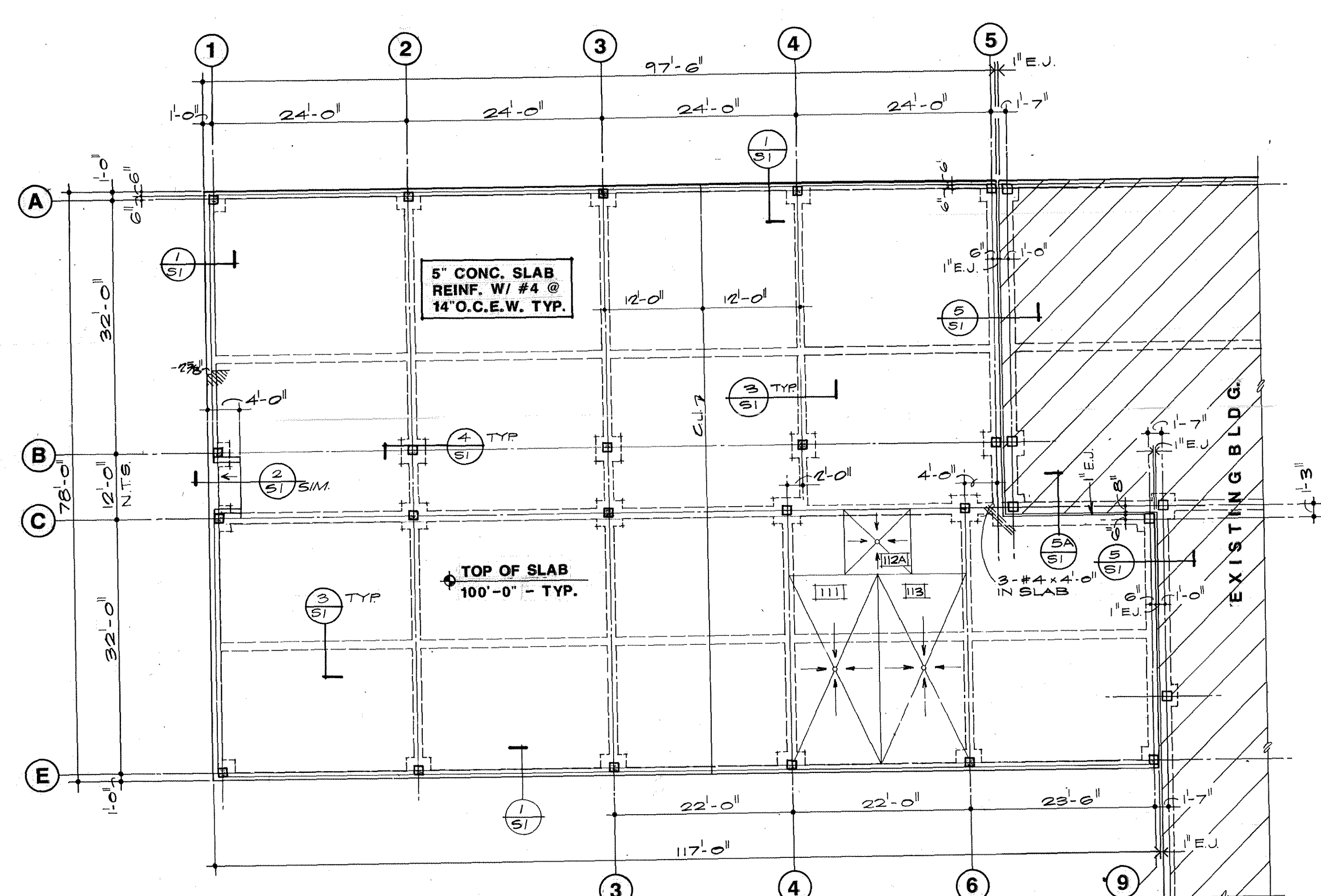

PARTIAL FOUNDATION PLAN
SCALE: 3/32" = 1'-0"

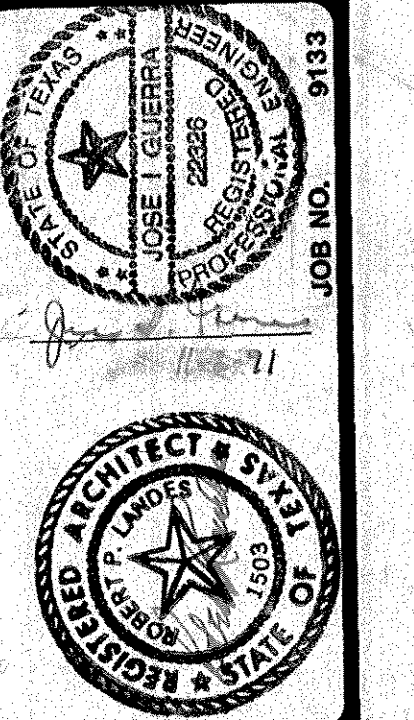

BLGY
INCORPORATED
ARCHITECTS-ENGINEERS-PLANNERS

1600 W. 38TH STREET SUITE 100 JEFFERSON BUILDING AUSTIN, TX 78731 (512) 451-8281

WILLOW SPRINGS
MOUNTAIN-VIEW
DUNCAN

FOUR ELEMENTARY
SCHOOL ADDITIONS

KILLEEN INDEPENDENT SCHOOL DISTRICT
KILLEEN TEXAS

PROJECT NUMBER
DATE 8 NOV 91

SHEET
S-1
OF 4

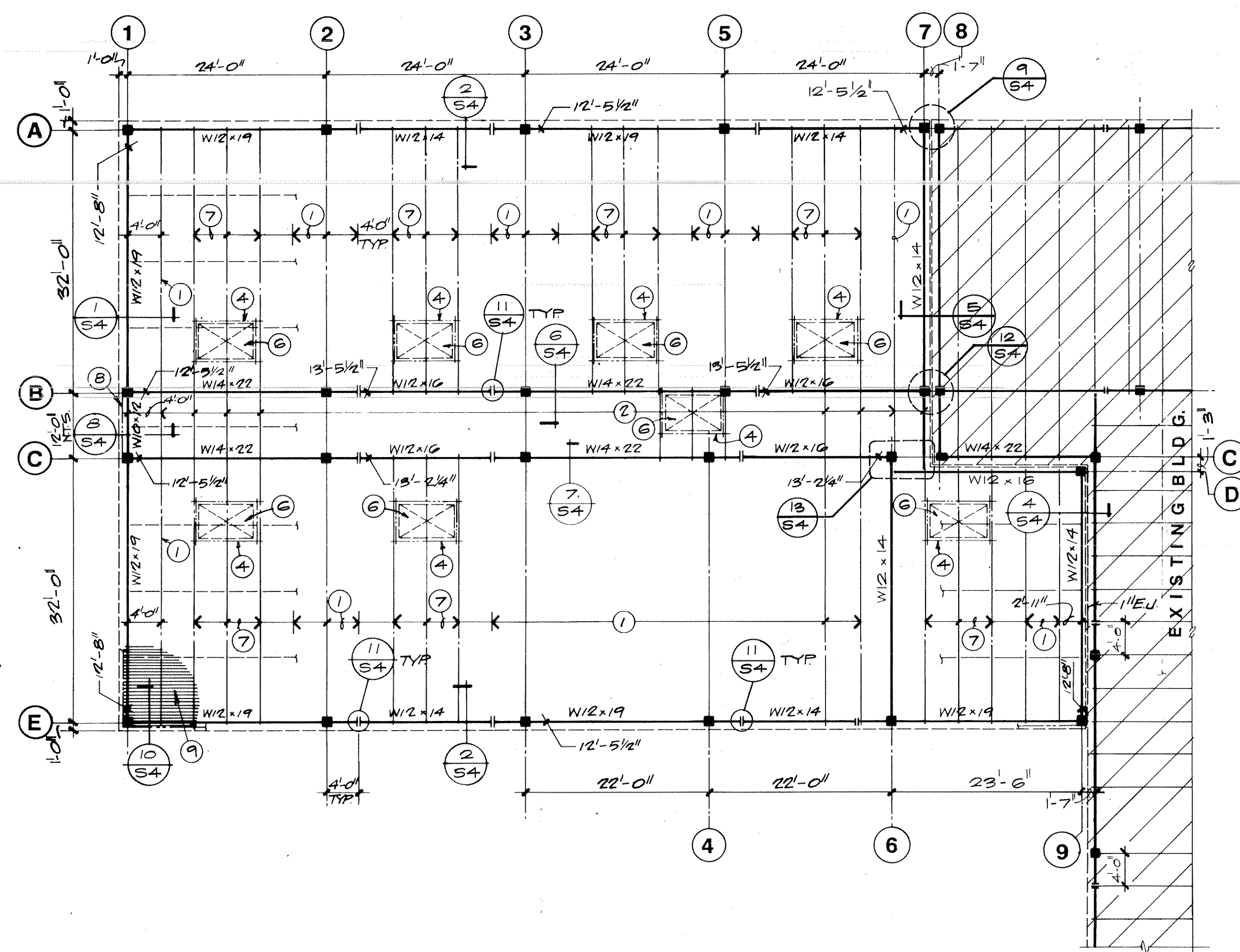

PARTIAL ROOF FRAMING PLAN

SCALE: 3/32" = 1'-0"

PLAN KEY NOTES

1. 16H5 OPEN WEB STEEL JOISTS @ 4'-0" o/c - THREE ROWS BRIDGING BY MFGR.
2. 8H3 OPEN WEB STEEL JOISTS @ 4'-0" o/c - ONE ROW BRIDGING BY MFGR
3. 8H3 OPEN WEB STEEL JOISTS @ 4'-0" o/c - TWO ROWS BRIDGING BY MFGR.
4. ANGLE FRAMING 3x3x1/4 WELDED TO TOP CHORD OF JOISTS.
5. FASCIA - REFER ARCHITECTURAL.
6. ROOF TOP MECH. UNIT - MAX. WT. = 860 LBS. LOCATE SO THAT DUCT WORK DOES NOT CONFLICT WITH JOISTS.
7. 16H7 OPEN WEB STEEL JOISTS @ 4'-0" o/c - THREE ROWS BRIDGING BY MFGR.
8. C8x11.5 AT 8'-8" ABOVE FINISH FLOOR.
9. 26 GA, GALVANIZED TYPE 1.0 CSV FORM DECK.

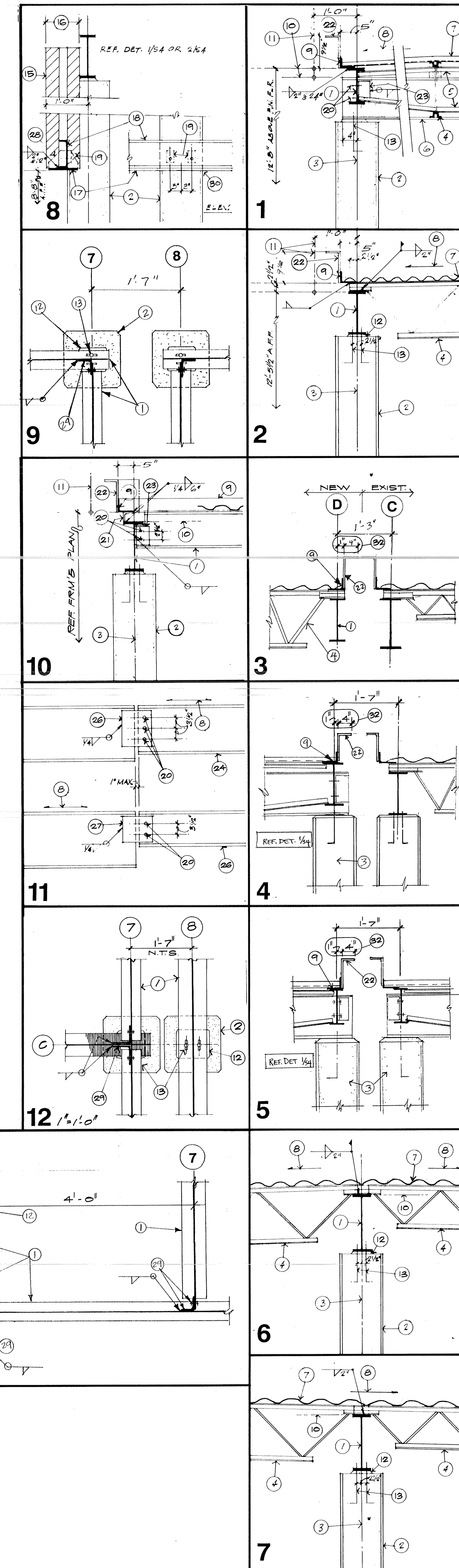

KEY NOTES

1. STEEL BEAM - REF. FRAMING PLAN SHT. S-4.
2. CONC. COL. W/ 3/4" CHAMFER.
3. BEAM & COLUMN.
4. STEEL BAR JOIST - REF. FRAMING PLAN.
5. JOIST BRIDGING - REF. FRAMING PLAN.
6. STEEL BEAM BEYOND.
7. 26 GA. TYPE 1.0 CSV GALV. ROOF DECK BY "VULCRAFT" OR APPROVED ABOVE.
8. REF. ROOF FRAMING PLAN FOR ROOF SLOPE.
9. L3x4x1/4 CONT.
10. ELEV. TOP STEEL BEAM ABOVE FIN. FLR. - REF. FRAMING PLAN.
11. LINE OF EXTERIOR BRICK FACE - REF. ARCH'L.
12. 1" MIN. TO 2" MAX. NON-SHRINK GROUT.
13. 3/4" x 12" ANCHOR BOLTS ONE EACH SIDE OF WEB IN 2" SLOPE.
14. L5x5x1/4 CONT.
15. BRICK FASCIA WALL - REF. ARCH'L.
16. WALL WIDTH - W - REF. ARCH'L.
17. 3/8" x (W-1) P CONT.
18. C8x11.5 CONT.
19. CONC. INSERT - USE 2-3/4" STD PEERLESS WEDGE INSERT BY "RICHMOND" OR APPROVED EQUAL.
20. 3/4" BOLTS IN 1 1/2" SLOTS.
21. L3x3x1/4x6" W/ 1/4" STIFF. PL.
22. WELDED PL 1/4" x 9" x 6" @ 48" o/c.
23. L4x4x3/8x5"
24. W14 OR W16 BEAM.
25. W10 OR W12 BEAM.
26. 3/8"x8"x10" PL.
27. 3/8"x8"x8" PL.
28. 1/4" STIFF PL EACH SIDE @ 24" o/c.
29. L4x4x3/8x10" (FOR W14 OR W16 BEAM) & 3-3/4" BOLTS IN 2" SLOTS, OR L4x4x3/8x7" (FOR W10 OR W12 BEAM) & 2-3/4" BOLTS IN 1 1/2" SLOTS.
30. NOTCH PL TO CLEAR COLUMN.
31. L6x4x3/8x10" W/ 3-3/4" BOLTS IN 2" SLOTS.
32. VERIFY DIMENSIONS WITH ARCH'L.

JOSE G. VILLARREAL
REGISTERED PROFESSIONAL ENGINEER
STATE OF TEXAS
LICENSE NO. 22220

BLGY INCORPORATED
ARCHITECTS-ENGINEERS-PLANNERS
STATE OF TEXAS
LICENSE NO. 22220

BLGY
INCORPORATED
ARCHITECTS-ENGINEERS-PLANNERS

1600 W. 38TH STREET SUITE 100 JEFFERSON BUILDING AUSTIN, TX 78731 (512) 451-8881

FOUR ELEMENTARY
SCHOOL ADDITIONS
INDEPENDENT SCHOOL DISTRICT
TEXAS

KILLEEN
KILLEEN

HAY BRANCH
WILLOW SPRINGS
MOUNTAIN VIEW
DUNCAN

PROJECT NUMBER
DATE 8 Nov. 91

SHEET
S-4
OF 4

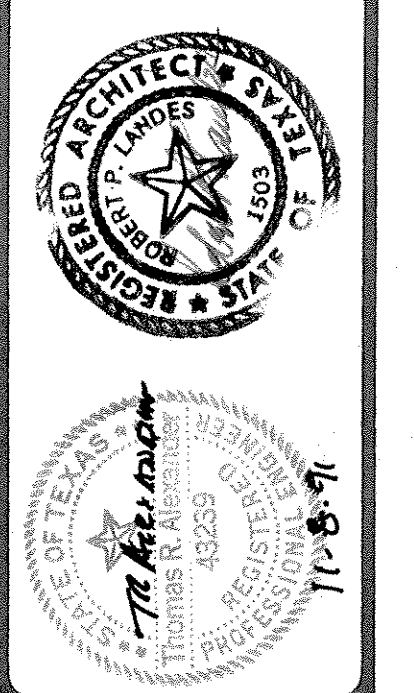

TALEX, INC.
CONSULTING MECHANICAL-ELECTRICAL ENGINEERS

BLGY
NEWSPAPER
ARCHITECTS ENGINEERS PLANNERS 1600 W. 38TH STREET SUITE 100 JEFFERSON BUILDING AUSTIN, TX 78731 (512)451-8881

FOUR ELEMENTARY SCHOOL ADDITIONS
INDEPENDENT SCHOOL DISTRICT TEXAS
KILLEEN KILLEEN

PROJECT NUMBER
DATE 11-8-91
SHEET
MP-2
OF

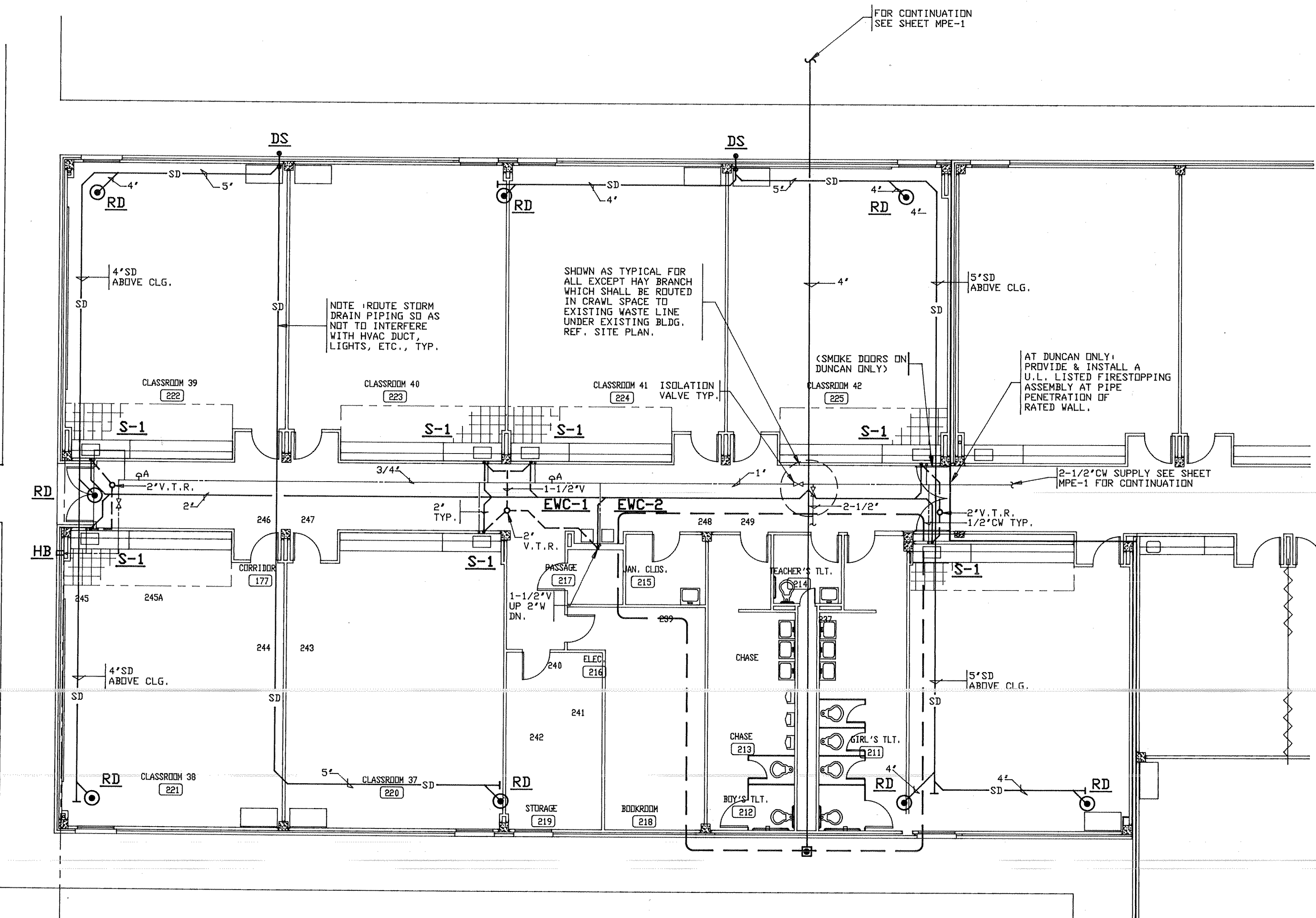

01 PLUMBING PLAN
SCALE: 1/8" = 1'-0"

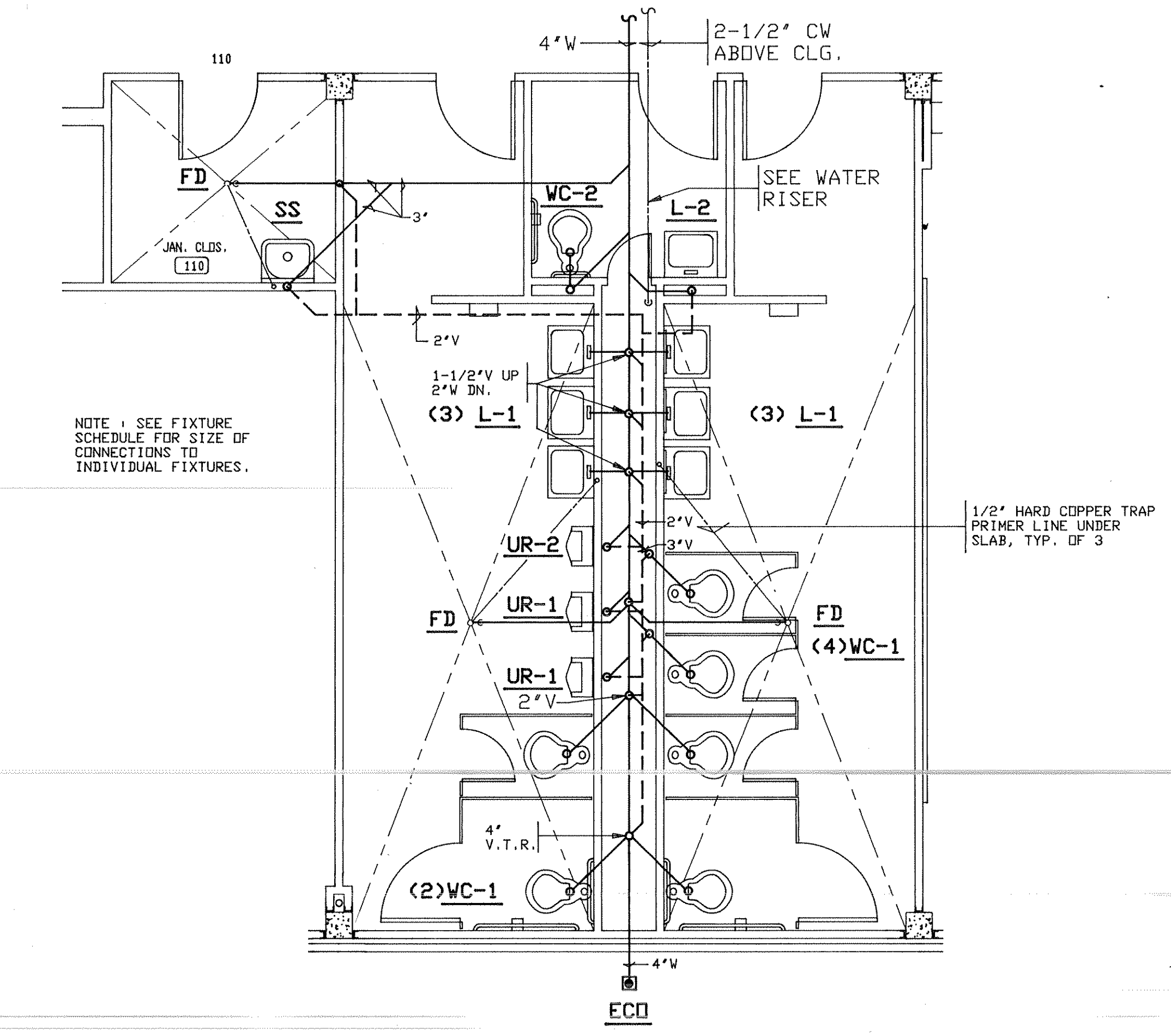

03 PARTIAL PLUMBING PLAN
SCALE: 1/8" = 1'-0"

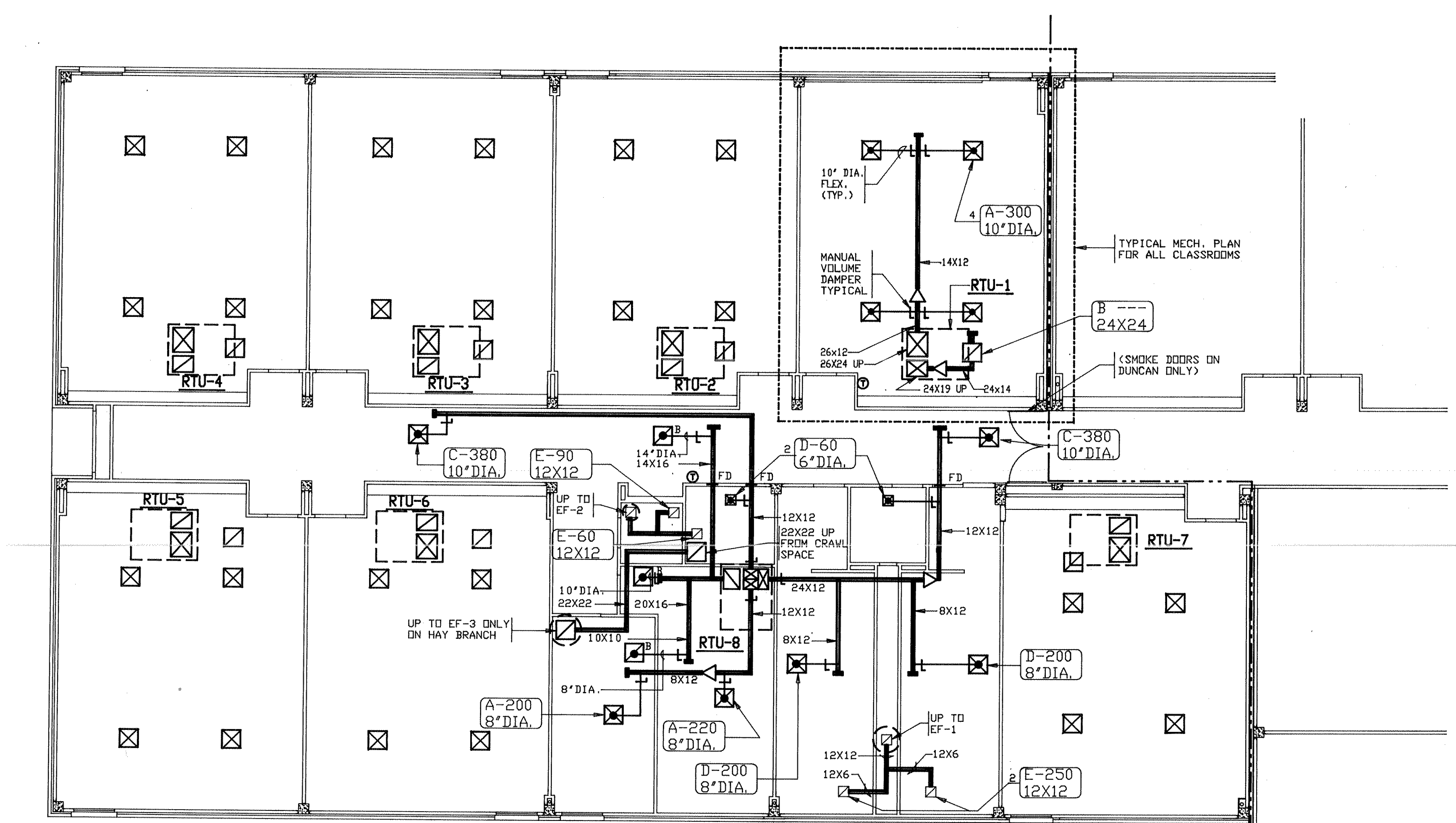

02 MECHANICAL PLAN
SCALE: 1/8" = 1'-0"

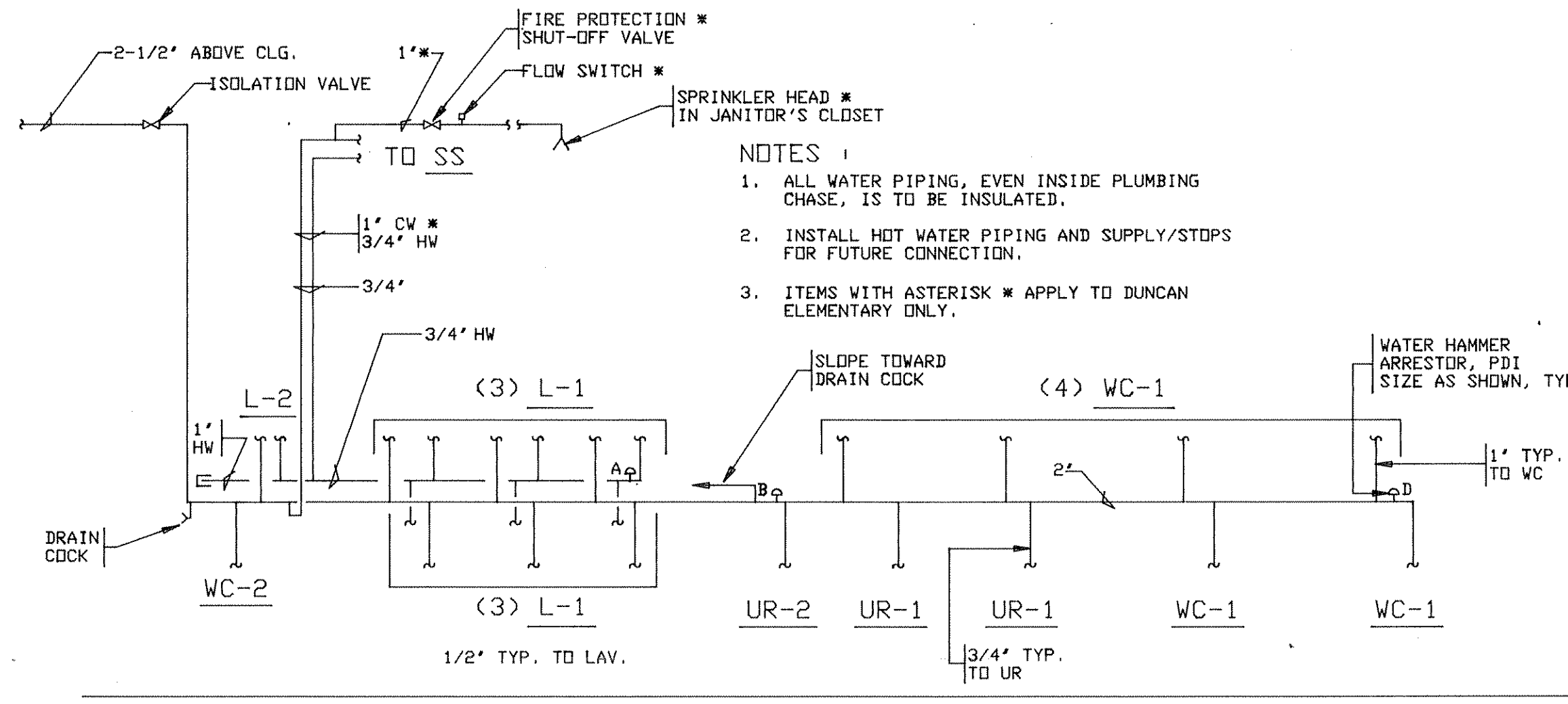

A WATER RISER DIAGRAM
SCALE: NONE

SYMBOL LEGEND

- ☒ SUPPLY AIR DIFFUSER
- ☒ RETURN AIR DIFFUSER
- FD ONE LINE DUCTWORK
- FD FIRE DAMPER
- ⊙ THERMOSTAT
- ⊙ POINT OF NEW CONNECTION
- RD ROOF DRAIN
- ⊙ EXTERIOR CLEAN-OUT
- WASTE LINE
- VENT LINE
- COLD WATER LINE
- SD STORM DRAIN LINE
- G GAS LINE
- D DRAIN LINE

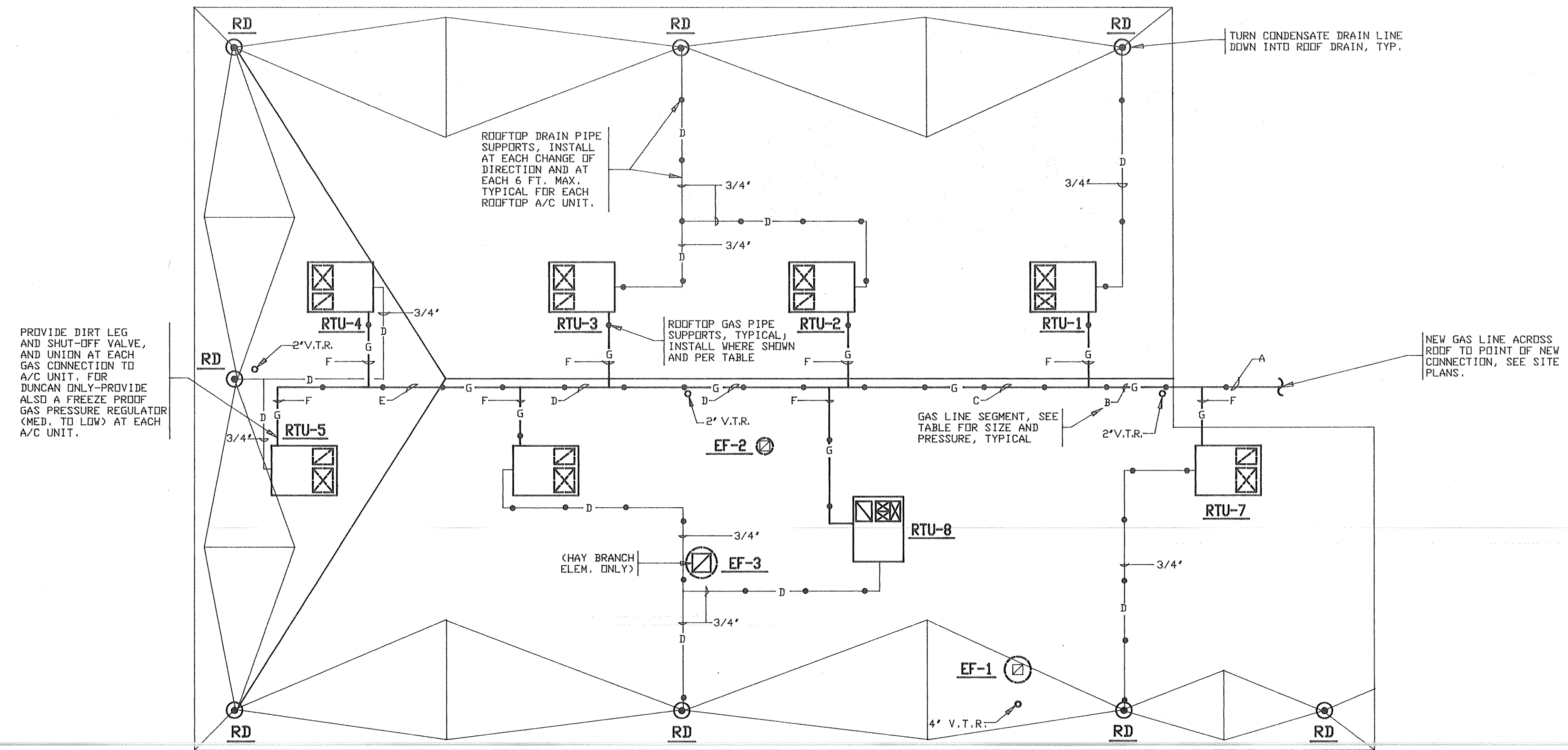

SCHOOL	SEGMENT	SIZE	PRESSURE
HAY BRANCH	A	2-1/2"	LOW
	B	2-1/2"	
	C	2"	
	D	2"	
	E	1-1/4"	
	F	1"	
DUNCAN	A	1"	MEDIUM
	B	1"	
	C	3/4"	
	D	3/4"	
	E	3/4"	
	F	3/4"	

GAS PIPE SUPPORT SPACING

PIPE SIZE UP TO	FT., MAX.
1-1/4"	9
1-1/2"	12
2"	13
2-1/2"	14

01 ROOF PLAN - MECHANICAL
SCALE: 1/8" = 1'-0"

PLUMBING GENERAL NOTES :

- A. SUPPORT SYSTEM FOR ALL PIPING MATERIALS AND EQUIPMENT SUPPORTED BY THE BUILDING STRUCTURE SHALL BE SUBMITTED TO THE STRUCTURAL ENGINEER AND ARCHITECT FOR APPROVAL PRIOR TO PURCHASE AND INSTALLATION.
- B. STORE ALL PIPES AND DEVICES ABOVE GROUND OR ABOVE SLAB.
- C. CONTRACTOR SHALL TAKE PRECAUTIONS PER THE ARCHITECT'S INSTRUCTIONS TO PROTECT EXISTING TREES AND /OR OTHER SITE VEGETATION.
- D. CONTRACTOR SHALL NOT CUT, DRILL, OR ALTER ANY ELEMENT OF A WALL, FLOOR, CEILING, ROOF, SLAB, ETC., WITHOUT FIRST RECEIVING INSTRUCTIONS FROM ARCHITECT. ALL CUTS SHALL BE MADE WITH A CUTTING TOOL.
- E. SEE PLUMBING FIXTURE SCHEDULE FOR SIZES OF CONNECTIONS TO INDIVIDUAL FIXTURES.
- F. ALL PATCHING OR SEALING OF CUTS, PENETRATIONS, ETC., SHALL BE DONE BY CONTRACTOR PER INSTRUCTIONS FROM AND TO FINAL APPROVAL OF ARCHITECT.
- G. FOR CLEANOUTS EXTERIOR TO THE BUILDING, INSTALL CLEANOUTS IN 12"x12"x4" REINFORCED CONCRETE BLOCKING, WITH BEVELED EDGES AND LEVEL WITH GRADE.
- H. ALL CAST IRON PLUMBING TRAPS LOCATED BELOW SLAB OR IN CONCEALED PLACES SHALL BE THE DEEP SEAL TYPE.
- I. FIRESTOPPING OF PLUMBING PENETRATIONS IN FIRE-RATED WALLS SHALL BE BY FIRESTOPPING CONTRACTOR PER SPECIFICATIONS SECTION 07270. PLUMBING CONTRACTOR SHALL MINIMIZE THE SIZE OF PENETRATIONS AND SHALL MAKE NEAT, REGULAR HOLES FOR PENETRATIONS BY CUTTING WITH A CIRCULAR SAW. SLOPPY OR DESTRUCTIVE WORKMANSHIP SUCH AS MAKING A PENETRATION BY KNOCKING A LARGE AND/OR IRREGULAR HOLE WITH A HAMMER, IS NOT ACCEPTABLE.

MECHANICAL GENERAL NOTES:

- A. MECHANICAL CONTRACTOR SHALL COORDINATE WITH ELECTRICAL CONTRACTOR THE ELECTRICAL REQUIREMENTS, INCLUDING POWER, CONTROL, COMMUNICATION, AND MONITORING, OF EACH DEVICE PROVIDED AND/OR INSTALLED BY MECHANICAL CONTRACTOR.
- B. SUPPORT SYSTEM FOR ALL PIPING MATERIALS AND EQUIPMENT SUPPORTED BY THE BUILDING STRUCTURE SHALL BE SUBMITTED TO THE STRUCTURAL ENGINEER AND ARCHITECT FOR APPROVAL PRIOR TO PURCHASE AND INSTALLATION. NO WIRE OR PERFORATED STRAP WILL BE PERMITTED FOR ANY HANGER OR SUPPORT.
- C. FLEXIBLE DUCT SHALL BE INSULATED TYPE (PER SPECS) AND ANY ONE PIECE SHALL NOT EXCEED 8'-0" IN LENGTH. EACH TAP FOR FLEXIBLE DUCT SHALL BE MADE WITH A FACTORY MADE SPIN-IN (DOVE-TAIL NOT ALLOWED) SHEETMETAL COLLAR. EACH TAP FOR SUPPLY AIR SHALL HAVE AN INTEGRAL BALANCING DAMPER WITH EXTENDED LENGTH OPERATOR. FLEXIBLE DUCT SHALL BE THE SAME SIZE AS THE NECK SIZE OF THE AIR DEVICE SERVED UNLESS SHOWN OTHERWISE.
- D. CONTRACTOR SHALL INSULATE METAL PARTS OF SUPPLY AIR DEVICES WITH 1-1/2" FIBERGLASS WRAP INSULATION WITH FOIL VAPOR BARRIER.
- E. BEFORE INSTALLATION, EQUIPMENT AND DEVICES INCLUDING, BUT NOT LIMITED TO, ANY DEVICE WITH ELECTRICAL CONNECTIONS, DUCTWORK, INSULATION, PIPING, AIR DEVICES, VALVES, ETC., SHALL NOT BE STORED DIRECTLY ON GRADE OR ON A SLAB OR FLOOR. BEFORE AND AFTER INSTALLATION, SUCH EQUIPMENT AND DEVICES SHALL BE PROTECTED FROM ENTRY OF DIRT, TRASH, WATER (EXCEPT AS REQUIRED), VERMIN, ETC..
- F. DURING STORAGE ON SITE, ALL FABRICATED DUCTWORK SHALL BE PROTECTED FROM ELEMENTS DURING PERIODS OF NO WORK, INCLUDING OVERNIGHT. DUCT SHALL BE STORED ABOVE GRADE OR SLAB AND SHALL BE COVERED.
- G. CONTRACTOR SHALL COORDINATE ACTUAL LOCATIONS OF ALL AIR DEVICES AND DUCTWORK WITH LIGHTS, CEILING PANELS, JOIST SPACING AND ARCHITECTURAL REFLECTED CEILING PLAN (REF ELECTRICAL PLANS AND ARCHITECTURAL PLANS).
- H. CONTRACTOR SHALL NOT CUT, DRILL, OR ALTER ANY ELEMENT OF A WALL, FLOOR, CEILING, ROOF, SLAB, ETC., WITHOUT FIRST RECEIVING INSTRUCTIONS FROM ARCHITECT PER SPECIFICATIONS. ALL CUTS SHALL BE MADE WITH A CUTTING TOOL.
- I. ALL PATCHING OR SEALING OF CUTS, PENETRATIONS, ETC., SHALL BE DONE BY CONTRACTOR PER INSTRUCTIONS FROM AND TO FINAL APPROVAL OF ARCHITECT. COORDINATE WITH GENERAL CONTRACTOR.
- J. DUCTWORK DIMENSIONS ARE SHEETMETAL SIZES. DUCTWORK TO BE LINED WITH 1" INTERNAL INSULATION. DUCT CONSTRUCTION, SUPPORT, FITTINGS, CONNECTION, ETC., SHALL BE IN CONFORMANCE WITH SMACNA HVAC DUCT CONSTRUCTION STANDARDS, FIRST EDITION, 1985. DUCT SHALL BE CONSTRUCTED FOR +/- 1" WG OF STATIC PRESSURE. ALL TRANSVERSE JOINTS, LONGITUDINAL SEAMS, AND DUCT WALL PENETRATIONS SHALL BE SEALED PER SPECIFICATIONS.
- K. ALL WORK SHALL COMPLY WITH SMACNA STANDARDS, STANDARD MECHANICAL CODE, AND LOCAL ENERGY AND SAFETY REQUIREMENTS.
- L. ANY PIPING ROUTED ON THE ROOF SHALL BE SUPPORTED BY FACTORY MADE PIPE SUPPORTS PER SPECIFICATIONS.

TALEX, INC.
 CONSULTING MECHANICAL-ELECTRICAL ENGINEERS

BLGY
 ARCHITECTS ENGINEERS PLANNERS
 1600 W. 38TH STREET SUITE 100
 JEFFERSON BUILDING AUSTIN, TX 78731 (512)451-8881

KILLEEN INDEPENDENT SCHOOL DISTRICT
 TEXAS
 FOUR ELEMENTARY SCHOOL ADDITIONS

PROJECT NUMBER
 DATE 11-8-91
 SHEET
 MP-3
 OF 6

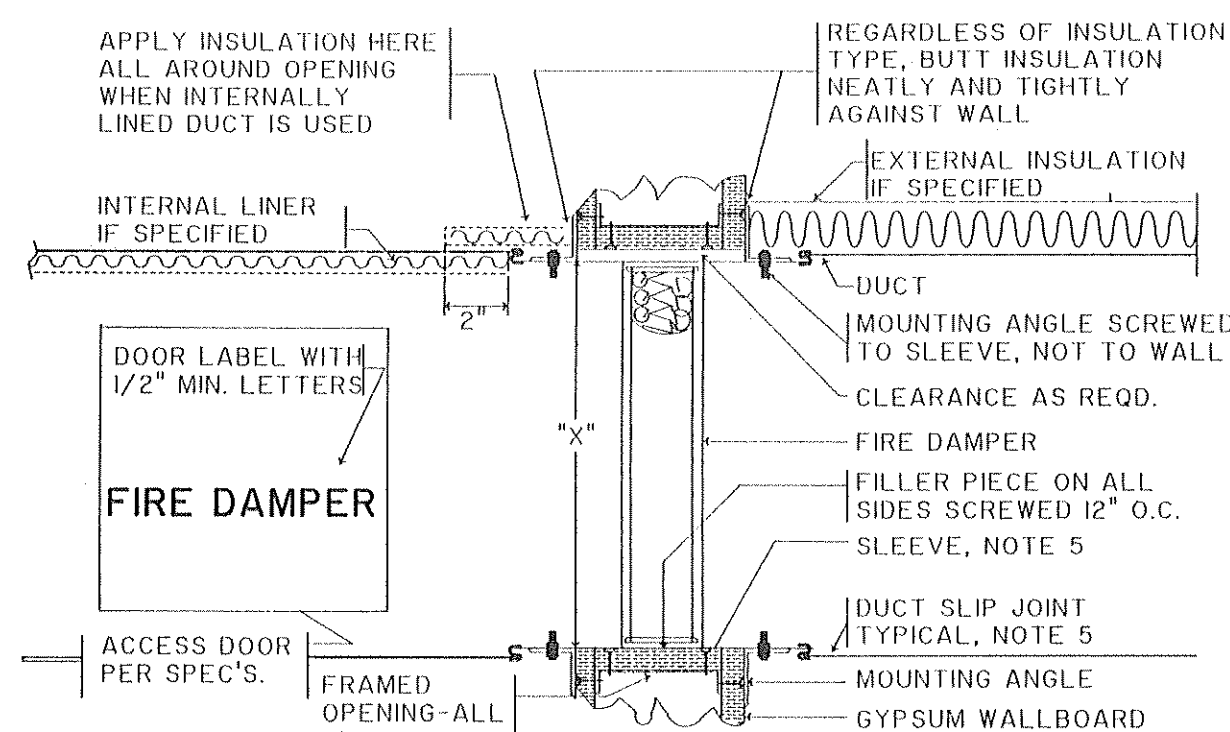

B WALL FIRE DAMPER DETAIL
SCALE: NONE

NOTES:

- THIS DETAIL IS NOT INTENDED NOR REPRESENTED TO BE COMPLETE. ACTUAL INSTRUCTIONS AS TO MATERIALS, DIMENSIONS, METHODS, ETC., INSTALLATION SHALL CONFORM TO MANUFACTURER'S WRITTEN INSTALLATION.
- CONTRACTOR SHALL OBTAIN AND PROVIDE TO THE GENERAL CONTRACTOR A COMPLETE SET OF MANUFACTURER'S INSTALLATION INSTRUCTIONS INCLUDING ANY WALL FRAMING REQUIRED TO ACCEPT THE FIRE DAMPER.
- THE ILLUSTRATIVE DETAIL ABOVE SHOWS A TYPE "A" CURTAIN FIRE DAMPER. OTHER TYPES OF FIRE DAMPERS OR COMBINATION FIRE/SMOKE DAMPERS WILL HAVE SIMILAR INSTALLATIONS. COMPLY WITH NOTE 1 AND 2 IF OTHER TYPES OR STYLES ARE USED. TYPE "A" MAY BE USED ONLY IF DIMENSION "C" IS MORE THAN 16 INCHES.
- THE ILLUSTRATIVE DETAIL ABOVE SHOWS A ONE-HOUR RATED WALL WITH GYPSUM BOARD AND METAL STUDS. IF OTHER WALL TYPES OR RATINGS ARE USED, COMPLY WITH NOTE 1 AND 2.
- SLEEVE GAGE SHALL BE NO LESS THAN DUCT GAGE AS REQUIRED BY SMACNA DUCT CONSTRUCTION STANDARD. DUCT-SLEEVE CONNECTION SHALL BE PLAIN "S" SLIP, DOUBLE "S" SLIP, INSUL. SLIP JOINT, HEATED "S" SLIP, STANDING "S" SLIP, OR REINFORCED STANDING "S" SLIP AS DEFINED BY SMACNA. SLEEVE-DUCT CONNECTION SHALL BE NO MORE THAN 6" FROM WALL ON ALL SIDES UNLESS SPECIFICALLY ALLOWED OTHERWISE IN MFR'S INSTALLATION INSTRUCTIONS.

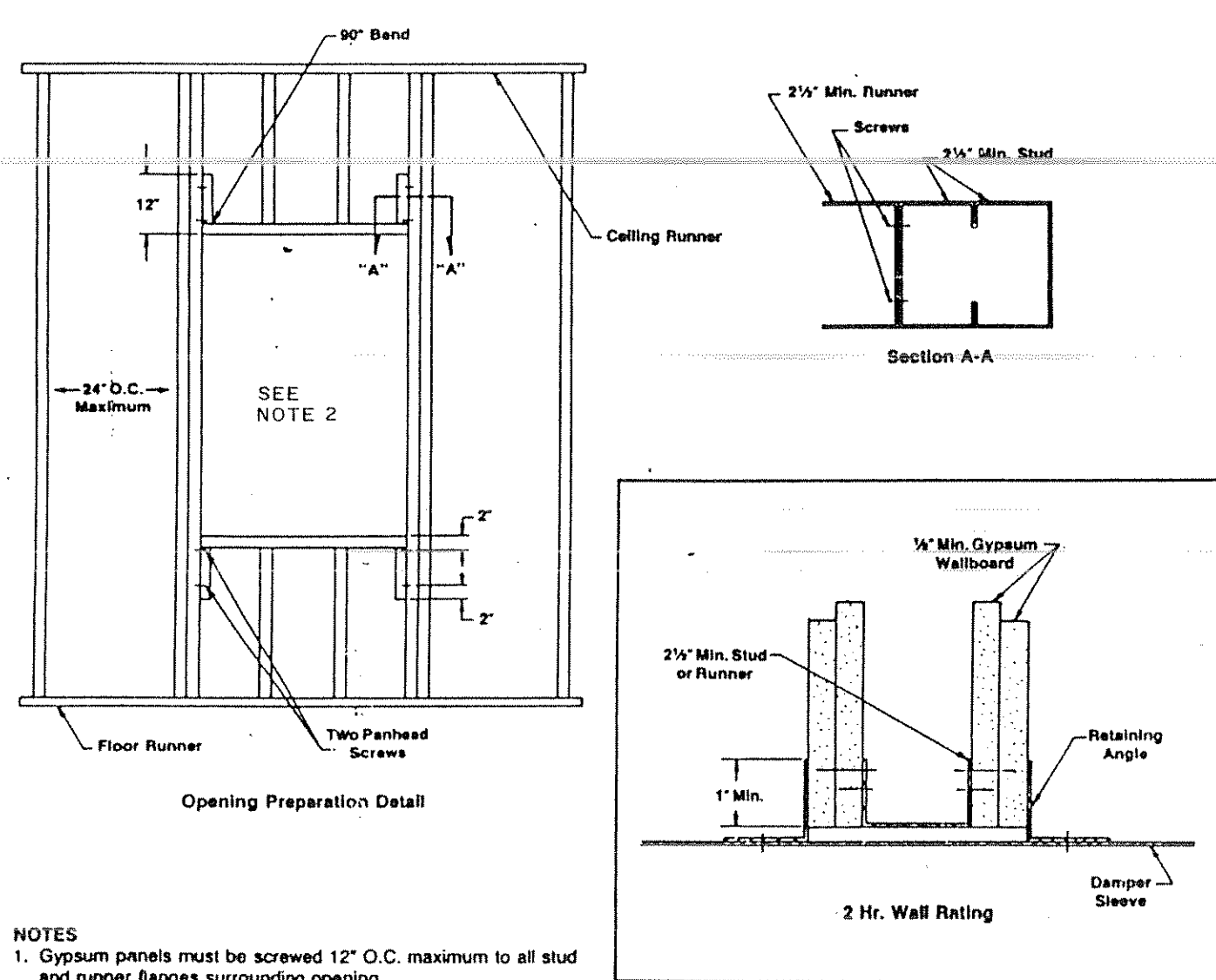

C METAL STUD FRAMING FOR FIRE DAMPER
SCALE: NONE

NOTES:

- Gypsum panels must be screwed 12" O.C. maximum to all stud and runner flanges surrounding opening.
- Size of each opening shall be closely coordinated with size of fire damper.

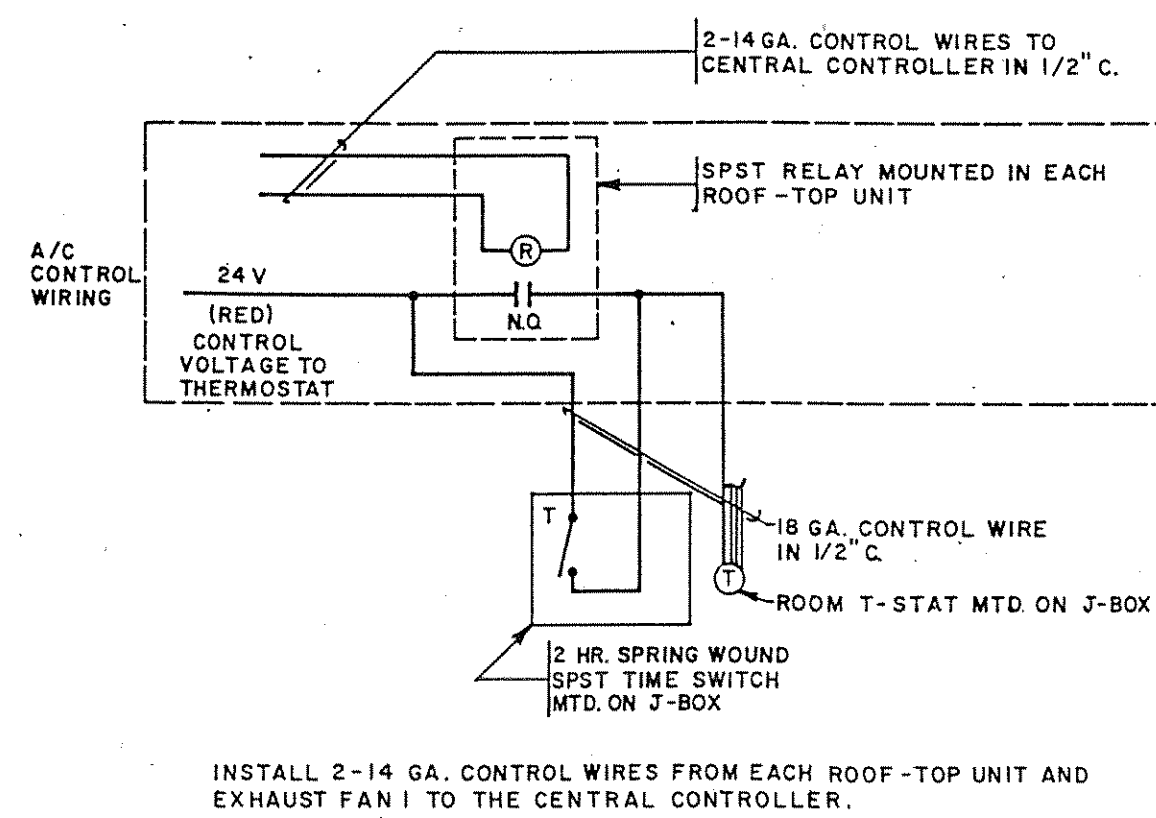

D CENTRALIZED A/C UNIT CONTROL SCHEMATIC
SCALE: NONE

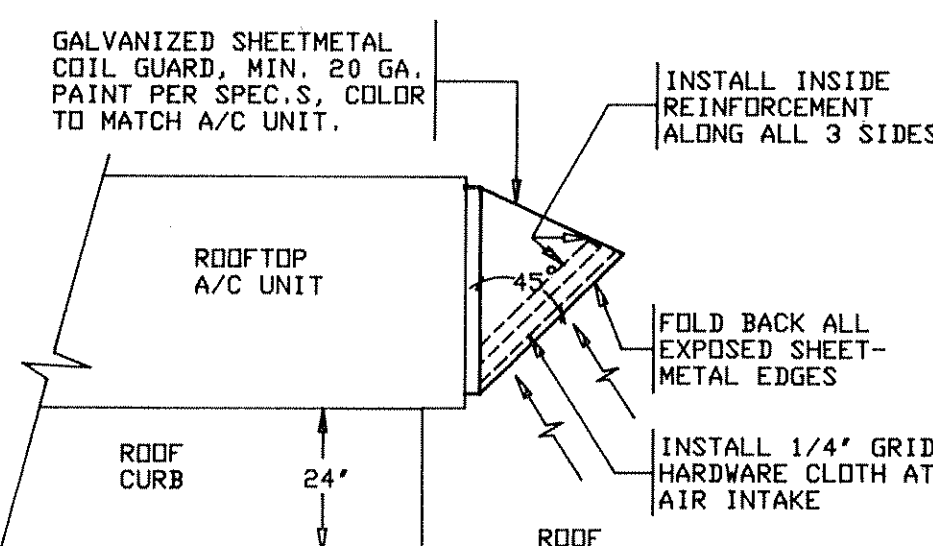

E CONDENSER COIL HAIL GUARD DETAIL
SCALE: NONE

AIR DEVICE SCHEDULE

MARK	TYPE	DESCRIPTION	MFR/MODEL
A	CEILING SUPPLY DIFFUSER	SQUARE STEPPED CONES, FRAME FOR LAY-IN CEILING GRID, 24"x24" NOMINAL SIZE, 4-WAY THROW	TITUS TMS
B	CEILING RETURN GRILLE	PERFORATED FACE, FRAME FOR LAY-IN CEILING GRID, 24"x24" NOMINAL SIZE	J&J MODEL 12-P
C	CEILING SUPPLY DIFFUSER	SIMILAR TO TYPE 'A' EXCEPT WITH BLANK-OFF BAFFLES TO FORM TWO-WAY THROW	TITUS TMS WITH BLANK-OFF BAFFLES
D	CEILING SUPPLY DIFFUSER	SQUARE STEPPED CONES, FRAME FOR SURFACE MOUNTING, 12"x12" NOMINAL FACE SIZE, BLANK-OFF BAFFLE TO FORM 3-WAY THROW	TITUS TMS WITH BLANK-OFF BAFFLE
E	CEILING EXHAUST REGISTER	PERFORATED FACE, FRAME FOR SURFACE MOUNTING, OPPOSED BLADE VOLUME DAMPER	J&J MODEL 12-P WITH OBD

NOTES:

- TITUS, METAL-AIRE, AND KRUEGER ARE PREAPPROVED EQUIVALENT MANUFACTURERS.
- EACH CEILING AIR DEVICE IS TO BE ALL STEEL.
- EACH ROUND NECK CEILING AIR DEVICE SHALL BE PROVIDED AND INSTALLED WITH A U.L. LISTED ROUND CEILING FIRE DAMPER WITH A THERMAL BLANKET.
- EACH SQUARE NECK CEILING AIR DEVICE SHALL BE PROVIDED AND INSTALLED WITH A U.L. LISTED SQUARE CEILING FIRE DAMPER WITH A THERMAL BLANKET.

PACKAGED A/C UNIT SCHEDULE

MARK	TYPE	RTU-1 thru 7	RTU-8
TYPE		GAS-FIRED	GAS-FIRED
AIRSIDE:			
DISCHARGE	DOWN	DOWN	DOWN
TOTAL CFM	1200	1700	2200
O.A. CFM	200	200	200
E.S.P. (IN. W.G.), NOTE 2	0.7	0.7	0.7
BLOWER MOTOR HP	1/2	3/4	3/4
FILTER (QTY/SIZE)	1/16x25x1	1/20x25x1	1/20x25x1
COOLING:			
MIN. TOT. CAP. MBH, NOTE 3	33.0	47.5	62.0
MIN. SENS. CAP. MBH, NOTE 3	25.0	38.7	51.0
CONDENSING TEMP./REFRIG. TEMP. (°C)	55/45	55/45	55/45
E.A.T. (DEG. F., DB/WB)	80/67	80/67	80/67
AMBIENT DEG. F.	105	105	105
MIN. SEER (EER), SEE NOTE 3	9.70(8.70)	9.70(8.70)	9.70(8.70)
HEATING:			
MIN. INPUT MBH	75.0	75.0	75.0
MIN. OUTPUT MBH	57.0	58.0	58.0
MIN. STAGES	1	1	1
MIN. AFUE	78.0	78.0	78.0
ELEC. REQUIREMENTS:			
VOLT/PH	480/3	480/3	480/3
MAX. OVERCURRENT PROT.	15	20	20
MIN. CIRCUIT AMPACITY	10.0	14.0	14.0
UNIT AND ACCESSORY WEIGHT, LBS.	500	655	655
MODEL NUMBER	GCS16-413-75	GCS16-513-75	GCS16-613-75
MANUFACTURER	LENNOX	LENNOX	LENNOX

NOTES:

- TRANE, CARRIER, LENNOX, AND YORK SHALL BE CONSIDERED EQUIVALENT MANUFACTURERS. HEAT EXCHANGERS SHALL HAVE MINIMUM 15 YEAR WARRANTY; REFRIGERANT COILS SHALL BE COPPER.
- EXTERNAL STATIC PRESSURE INCLUDES PLENUMS, DUCTWORK, AIR DEVICES, DAMPERS, WET COIL, AND FILTER(S).
- COOLING CAPACITIES ARE RATED AT EAT AND AMBIENT AS LISTED. SEER (OR EER) ARE AT A.R.I. CONDITIONS.
- EACH UNIT SHALL BE PROVIDED AND INSTALLED WITH A THERMOSTAT WHICH SHALL HAVE A 3 STAGE COOL/1 STAGE HEAT WITH AUTOMATIC CHANGEOVER AND LOCKING FROSTED COVER.
- PROVIDE EACH UNIT WITH AN INSULATED FACTORY ROOF CURB (MINIMUM 24" TALL), TEMPERATURE CONTROLLED 100% MODULATING ECONOMIZER CYCLE WITH INTERNAL OUTSIDE AIR FILTER(S), AND ANTI-SHORT CYCLE TIMER.
- PROVIDE AND INSTALL A FIRESTAY IN THE RETURN AIR STREAM AHEAD OF THE OUTSIDE AIR INTAKE FOR AUTOMATIC SHUT-DOWN.

PLUMBING FIXTURE SCHEDULE

MARK	MIN. CONNECTIONS	TYPE	FIXTURE	TRIM
	CW HW VENT WASTE			
WC-1	1" -- 2" 4"	FLOOR MOUNTED, BOTTOM OUTLET, ELONGATED BOWL, SIPHON JET ACTION, MAXIMUM 14" FROM RIM TO FINISHED FLOOR	KOHLER NO. K-4550-ET "WELL-COMME" WATER SAVER, WHITE SEAT W/O COVER, CHILDREN'S WATER CLOSET	KOHLER NO. K-4666-C EXTRA HEAVY DUTY, OPEN FRONT, ROYAL 115-3-VC FLUSH VALVE, 24" FROM TOP OF WC TO CENTER OF WATER INLET, WITH CAST WALL FLANGE WITH SETSCREW
WC-2	1" -- 2" 4"	FLOOR MOUNTED, BOTTOM OUTLET, FLUSH VALVE, ADULTS' WATER CLOSET	KOHLER NO. K-4268-ET "HIGH-CLIFF" WATER SAVER, ELONGATED BOWL, SIPHON JET ACTION, 113-3-VC FLUSH VALVE, 16" FROM TOP OF WC TO CENTER OF WATER INLET, WITH CAST WALL FLANGE WITH SETSCREW	KOHLER NO. K-4666-C EXTRA HEAVY DUTY, OPEN FRONT, WHITE SEAT W/O COVER; SLOAN ROYAL 115-3-VC FLUSH VALVE, 16" FROM TOP OF WC TO CENTER OF WATER INLET, WITH CAST WALL FLANGE WITH SETSCREW
UR-1	3/4" -- 1-1/2" 2"	WALL MOUNTED, CHILDREN'S URINAL	KOHLER NO. K-5014-T "DEXTER" WATER SAVER, FRONT MINIMUM 14" FROM WALL, INSTALL WITH RIM 17" ABOVE FINISHED FLOOR	SLOAN ROYAL 180-1.5 FLUSH VALVE, SEE NOTE 2 ALSO
UR-2	3/4" -- 1-1/2" 2"	WALL MOUNTED, HANDICAPPED ACCESSIBLE, CHILDREN'S URINAL	KOHLER NO. K-5014-T "DEXTER" WATER SAVER, FRONT MINIMUM 14" FROM WALL, INSTALL WITH RIM 14" ABOVE FINISHED FLOOR	SLOAN ROYAL 180-1.5 FLUSH VALVE, SEE NOTE 2 ALSO
L-1	1/2" NONE 1-1/2" 1-1/2"	CHILDREN'S WALL MOUNTED LAVATORY	KOHLER NO. K-1729 "CHESA-PEAKE", 20"x18" O.D., VITREOUS CHINA, DRILLED FOR CONCEALED ARM CARRIERS, MOUNT WITH MIN. 26" KNEE CLEARANCE AND MAX. 30" TO TOP, 4" FAUCET CENTERS	CHICAGO FAUCETS NO. 701 SELF-CLOSING FAUCET WITH NO. 369 2-1/2" LEVER HANDLES AND NO. E28 VANDAL RESISTANT 3/4 GPM AERATOR; MOORE NO. 128 C.P. FAUCET HOLE COVERS(2); KOHLER NO. K-7715 GRID STRAINER WITH TAILPIECE; SEE NOTES 2,3,4,6 & ALSO
L-2	1/2" NONE 1-1/2" 1-1/2"	ADULTS' WALL MOUNTED LAVATORY	SAME AS LAVATORY L-1 EXCEPT WITH 29" KNEE CLEARANCE	SAME AS LAVATORY L-1 EXCEPT WITH CHICAGO FAUCETS NO. 730-E28-369 FAUCET (SIMILAR TO NO. 701 BUT NOT SELF-CLOSING)
SS	3/4" NONE 2" 3"	WALL MOUNTED SERVICE SINK	KOHLER NO. K-6718 "BANNON" 22.25"x18.25"x12" DEEP, ENAMELED CAST IRON, BLANK BACK	KOHLER NO. K-8904 ROUGH PLATED FAUCET SET WITH VACUUM BREAKER, THREADED SPOUT, PAUL HOOK, WALL BRACE, & INTEGRAL STOPS; KOHLER NO. K-6673 BACK OUTLET P-TRAP WITH CLEANOUT PLUG AND STRAINER; SEE NOTES 2,3,4,6 & ALSO
S-1	1/2" NONE 1-1/2" 1-1/2"	COUNTERTOP CLASSROOM SINK	ELKAY NO. DRKR-2517, 18 GA. STAINLESS STEEL, FULLY UNDERDRAINED, 25 1/2" O.D. BY 7.5" DEEP, FAUCET LEDGE (ONE-HOLE PUNCHED) ON LEFT AND BUBBLER LEDGE ON RIGHT	ELKAY NO. LK-2085-13L SINGLE SUPPLY FAUCET WITH GOOSENECK SPOUT; ELKAY NO. LK-83 PUSH BUTTON BUBBLER; ELKAY NO. LK-188 STAINLESS STEEL PERFORATED STRAINER WITH 1-1/2" TAILPIECE; SEE NOTES 2,3,4,6 & ALSO
EWC-1	1/2" -- 1-1/2" 1-1/2"	WALL MOUNTED ELECTRIC WATER COOLER	ELKAY MODEL EWCA-14, WALL COMPACT MODEL, STAINLESS STEEL BASIN, 14.0 GPH, 360 WATTS, COLOR BY ARCHITECT; MOUNT WITH SPOUT 36" A.F.F.	SEE NOTES 2, 3, AND 4 ALSO
EWC-2	1/2" -- 1-1/2" 1-1/2"	WALL MOUNTED HANDICAPPED ACCESSIBLE ELECTRIC WATER COOLER	SAME AS EWC-1 EXCEPT WITH SPOUT MOUNTED MAXIMUM 32" ABOVE FLOOR	SEE NOTES 2, 3, AND 4 ALSO
FD-1	-- -- 2" 3"	FLOOR DRAIN W/ TRAP PRIMER	JAY R. SMITH FIG. 2010, CAST IRON BODY AND FLASHING COLLAR, WITH TRAP PRIMER TAP	JAY R. SMITH TYPE "B" 6" SQUARE NICKEL BRONZE TOP; JAY R. SMITH FIG. 2699 TRAP PRIMER VALVE; SEE NOTE 1
HB	3/4" -- -- --	EXTERIOR FREEZE-LESS HOSE BIBB	WOODFORD MODEL 65, CHROME FINISH ON BRASS CASTING, VACUUM BREAKER-BACKFLOW PREVENTER, HOSE THREADED SPOUT, LOOSE KEY OPERATOR	STEM FOR 18" WALL THICKNESS, CONTRACTOR SHALL VERIFY WALL THICKNESS AND PROVIDE LONGEST STEM POSSIBLE FOR MAXIMUM FREEZE PROTECTION
RD	-- -- -- --	ROOF DRAIN	JAY R. SMITH FIG. 1015-V, CAST IRON BODY, WIDE FLANGE, DEEP BODY, 4" NO-HUB OUTLET	CAST IRON DOME, UNDER DECK CLAMP, BUMP RECEIVER, CONTRACTOR SHALL COORDINATE ROOF DRAIN ACCESSORIES AND OPTIONS WITH ROOFING CONTRACTOR AND PROVIDE AS NEEDED
DS	-- -- -- --	ROOF DRAIN DOWNSPOUT NOZZLE	JAY R. SMITH FIG. 1770, CAST BRONZE BODY AND FLANGE, 5" INLET	
ECO	-- -- -- --	EXTERIOR CLEANOUT	JAY R. SMITH FIG. 4232, CAST IRON CLEANOUT, ROUND ADJUSTABLE SCORATED SECURED CAST IRON TOP, "C.O." CAST IN TOP	GASKET SEAL, IRON PLUG, VANDAL PROOF SCREWS

NOTES:

- EACH UNDERSLAB OR CONCEALED P-TRAP SHALL BE A DEEP-SEAL TYPE.
- EACH WALL-MOUNTED PLUMBING FIXTURE, SUCH AS SINKS, LAVATORIES, URINALS, DRINKING FOUNTAINS, ETC., SHALL BE PROVIDED AND INSTALLED WITH A FLOOR MOUNTED FIXTURE SUPPORT WITH RECTANGULAR LEGS. EACH URINAL FIXTURE SUPPORT SHALL ALSO HAVE A WATER BEARING PLATE. SEE SPECIFICATIONS ALSO.
- UNLESS SCHEDULED OTHERWISE, EACH LAVATORY OR SINK SHALL BE PROVIDED AND INSTALLED WITH P-TRAP ASSEMBLY CONSISTING OF C.P. CAST BRASS TRAP WITH CLEANOUT PLUG, C.P. BRASS NIPPLE, AND C.P. CAST BRASS ESCUTCHEON WITH SETSCREW.
- PROVIDE EACH FIXTURE THAT REQUIRES WATER (EXCEPT FLUSH VALVES) WITH A SUPPLY/STOP ASSEMBLY CONSISTING OF A C.P. BRASS STOP VALVE (MIN. 1/2") WITH LOOSE KEY HANDLE, C.P. FLEXIBLE RISER, C.P. BRASS NIPPLE, AND C.P. CAST BRASS ESCUTCHEON WITH SETSCREW. SEE SPECIFICATIONS ALSO.
- UNLESS SHOWN OTHERWISE, PROVIDE AND INSTALL A WATER HAMMER ARRESTOR IN AN ACCESSIBLE LOCATION ON EACH WATER LINE FOR EACH ISOLATED FIXTURE OR GROUP OF FIXTURES. AIR CHAMBERS ARE NOT ACCEPTABLE. SEE SPECIFICATIONS ALSO.
- FOR EACH LAVATORY OR SINK SCHEDULED FOR COLD WATER ONLY, PROVIDE AND INSTALL WITH TWO SUPPLY/STOPS PER NOTE 4. COLD WATER ONLY TO BE CONNECTED AT TIME OF CONSTRUCTION; HOT WATER TO BE PROVIDED FOR FUTURE CONNECTION.

FAN SCHEDULE

MARK	SERVES	LOCATION	TYPE	CFM	EXT.S.P.	DRIVE	H.P.	RPM	V/PH	MODEL NO.
EF-1	TOILETS	ROOF	CENTRIF	500	0.25	DIRECT	1/12th	1015	120/1	GREENHECK G-95-G
EF-2	JANITORY/ELEC RM	ROOF	CENTRIF	150	0.25	DIRECT	1/60th	1140	120/1	GREENHECK G-70-G
EF-3 (HAY BRANCH)	CRANL SPACE	ROOF	CENTRIF	3000	0.375	BELTED	1/2	900	120/1	GREENHECK GB 180-5

NOTES:

- ACME, GREENHECK, AND ILG ARE CONSIDERED EQUIVALENT MANUFACTURERS.
- EACH ROOF MOUNTED FAN SHALL BE PROVIDED AND INSTALLED WITH BIRDSCREEN, BACKDRAFT DAMPER, FACTORY MADE INSULATED ROOF CURB, AND DISCONNECT SWITCH.
- EACH ROOF CURB SHALL REQUIRE APPROVAL FROM ARCHITECT AS FAR AS STYLE, FINISH, ETC. IN ORDER TO MATCH ROOF TYPE. FOR INSTALLATION ON PITCHED ROOF, CURB SHALL MATCH THE PITCH SO THAT THE FAN IS INSTALLED LEVEL.
- EACH DIRECT DRIVE FAN SHALL BE PROVIDED AND INSTALLED WITH A SOLID STATE SPEED CONTROLLER. INSTALL SPEED CONTROLLER ON ROOF-MOUNTED FANS UNDER THE FAN HOOD. WIRING TO BE BY ELECTRICAL CONTRACTOR.

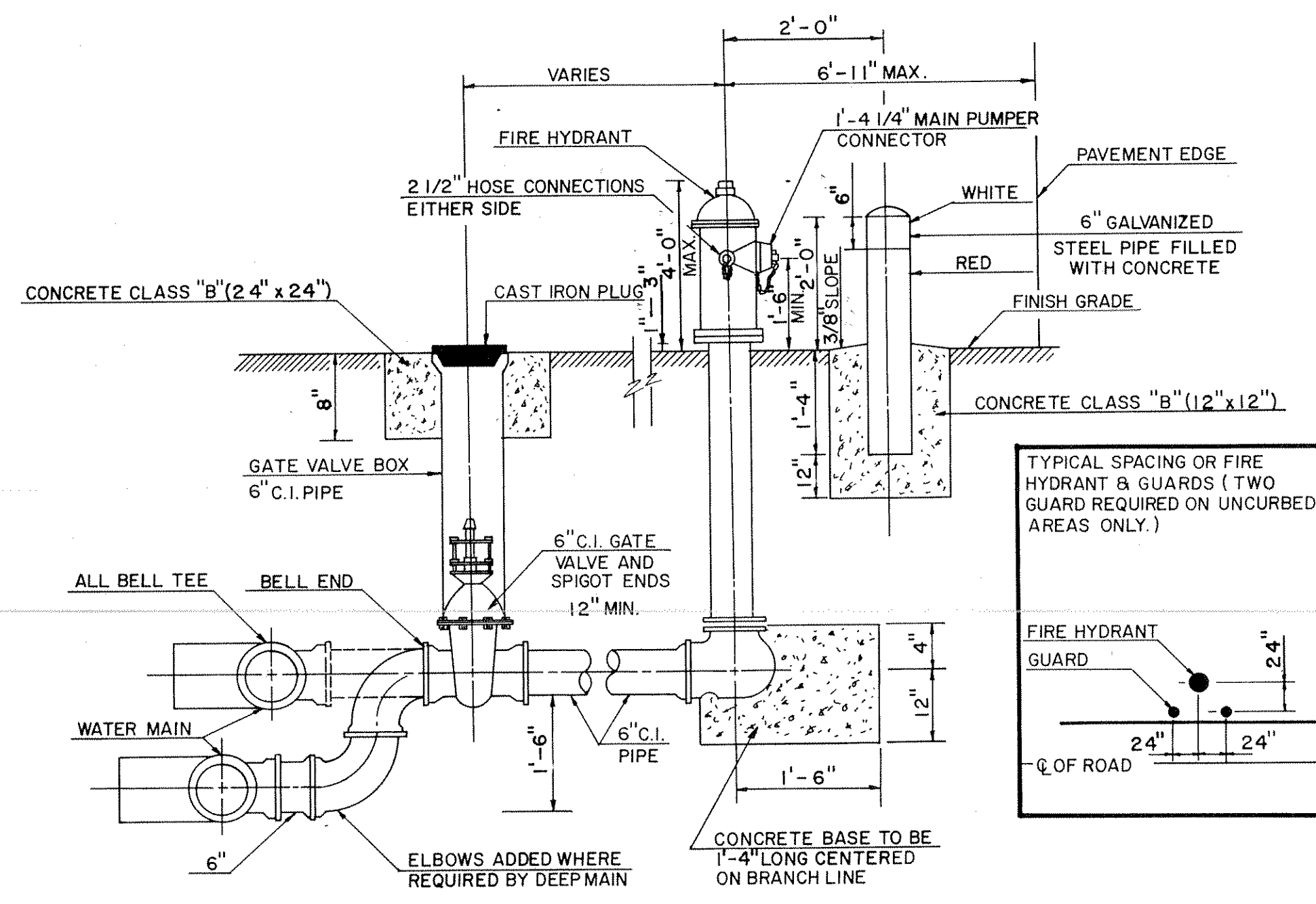

A FIRE HYDRANT DETAIL
SCALE: NONE

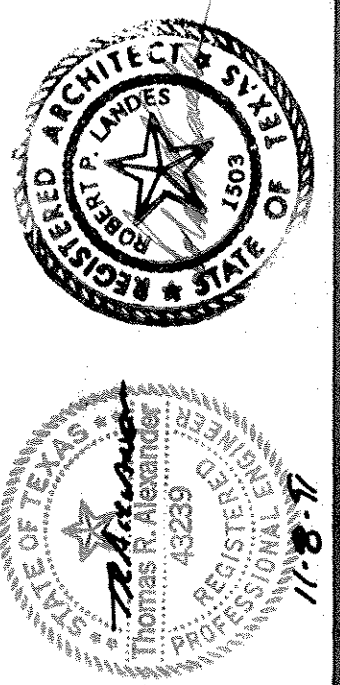

JEFFERSON BUILDING AUSTIN, TX 78731 (512) 451-8281
TALEX, INC.
CONSULTING MECHANICAL-ELECTRICAL ENGINEERS

BLG
INCORPORATED
ARCHITECTS ENGINEERS PLANNERS 1600 W. 38TH STREET SUITE 100
DALLAS, TEXAS 75241

FOUR ELEMENTARY SCHOOL ADDITIONS INDEPENDENT SCHOOL DISTRICT TEXAS
KILLEEN INDEPENDENT SCHOOL DISTRICT TEXAS

PROJECT NUMBER DATE 11-8-91

SHEET MP-4 OF 6

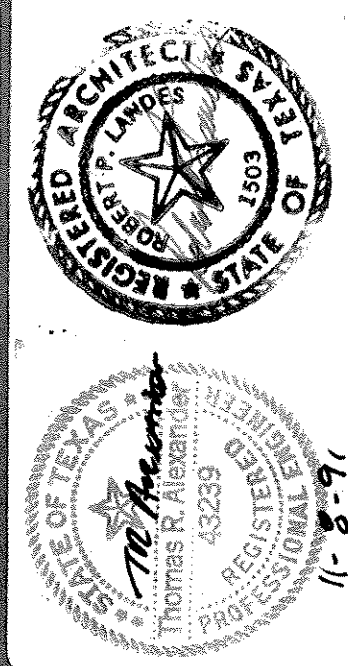

JEFFERSON BUILDING AUSTIN, TX 78731 (512)451-8281
TALEX, INC.
 CONSULTING MECHANICAL-ELECTRICAL ENGINEERS

BLGY
 ARCHITECTS-ENGINEERS PLANNERS 1600 W. 38TH STREET SUITE 100
 DALLAS, TEXAS 75241

DISTRICT TEXAS

FOUR ELEMENTARY SCHOOL ADDITIONS
 INDEPENDENT SCHOOL

KILLEEN KILLEEN

PROJECT NUMBER
 DATE 11-8-91

SHEET
E-2
 OF 6

COMMUNICATIONS SYMBOL SCHEDULE

SYMBOL	DESCRIPTION	SYMBOL	DESCRIPTION
⊙	CEILING MOUNTED SPEAKER	⊙	JUNCTION BOX ABOVE CEILING
⊙	HALL MOUNTED SPEAKER	⊙	JUNCTION BOX IN FLOOR BOX
⊙	MICROPHONE OUTLET	⊙	PUSHBUTTON, CALL-IN SWITCH
⊙	MICROPHONE OUTLET IN FLOOR BOX	⊙	ELECTRO-MAGNETIC DOOR HOLDER-FIRE ALARM
⊙	TELEPHONE OUTLET	⊙	HORN AND VISUAL DEVICE-FIRE ALARM
⊙	TELEPHONE OUTLET IN FLOOR BOX	⊙	FULL STATION-FIRE ALARM
⊙	TELEVISION OUTLET	⊙	LINE ADJACENT TO DEVICE INDICATES ZONE
⊙	TELEVISION OUTLET IN FLOOR BOX	⊙	SMOKE DETECTOR-FIRE ALARM
⊙	C.R.T. OUTLET	⊙	HEAT DETECTOR-FIRE ALARM
⊙	C.R.T. OUTLET IN FLOOR BOX	⊙	LINE ADJACENT TO DEVICE INDICATES ZONE
⊙	IMPACT MOUNTED SMOKE DETECTOR-FIRE ALARM	⊙	LINE ADJACENT TO DEVICE INDICATES ZONE
⊙	CEILING MOUNTED CLOCK (SINGLE FACE)	⊙	VISUAL DEVICE ONLY-FIRE ALARM
⊙	HALL BRACKET CLOCK (DOUBLE FACE)	⊙	AUXILIARY RELAY-FIRE ALARM
⊙	HALL BRACKET CLOCK, ELAPSED TIME	⊙	WATER FLOW SWITCH-FIRE ALARM
⊙	HALL BRACKET CLOCK, DAY AND DATE	⊙	LINE ADJACENT TO DEVICE INDICATES ZONE
⊙	TELEPHONE SYSTEM CONDUIT	⊙	TAMPER SWITCH OR O.S. AT VALVE-FIRE ALARM
⊙	TELEVISION SYSTEM CONDUIT	⊙	LINE ADJACENT TO DEVICE INDICATES ZONE
⊙		⊙	HORN
⊙		⊙	COMMUNICATIONS PANEL - FACP, INTERCOM, MASTER, ETC.

KEYED NOTES:

- REMOVE EXISTING SOFFIT LIGHTS AND EXIT SIGN AT EXISTING EXTERIOR DOOR.
- CONNECT NEW FIXTURE TO EXISTING CIRCUIT SERVING EXTERIOR LIGHTS, THRU EXISTING PHOTOCELL CONTROL.
- REMOVE EXISTING WEATHERPROOF RECEPTACLE AND ANY FIRE ALARM DEVICES (E.G. FULL STATION) THAT MAY EXIST.
- MOUNT RECEPTACLES AT HEIGHT SO THAT THEY ARE NOT VISIBLE AFTER INSTALLATION OF ELECTRIC WATER COOLERS.
- FIRE SPRINKLER WATER FLOW SWITCH AND TAMPER SWITCH ON DUNCAN ONLY. FIRE ALARM CONTRACTOR TO PROVIDE UL LISTED, FM APPROVED, WATER FLOW SWITCH AND CONNECTION FROM BOTH DEVICES TO EXISTING FIRE ALARM SYSTEM. SPRINKLER CONTRACTOR TO INSTALL WATER FLOW SWITCH INTO PIPING, AND PROVIDE TAMPER SWITCH WITH VALVE.
- TYPICAL FOR ALL EXHAUST FANS: PROVIDE NEMA 3R ENCLOSURE FOR SWITCH/STARTER AND CIRCUIT TO LVAA-8.

GENERAL NOTES:

- COORDINATE WORK WITH ALL OTHER TRADES GIVING SPECIAL CONSIDERATION TO WORK DONE ABOVE CEILINGS, OUTLET LOCATIONS AT MILLWORK, AND SWITCH LOCATIONS IN REGARDS TO DOOR SWINGS.
- PRODUCTS OF SIMILAR NATURE SHALL BE OF SAME TYPE AND MANUFACTURER.
- ALL WIRING SHALL BE #12 AWG, THW OR THHN, COPPER, IN MINIMUM 3/4" CONDUIT WITH GROUND WIRE, UNLESS NOTED OTHERWISE. USE OF CONDUIT GROUND IS UNACCEPTABLE.
- VERIFY ALL DIMENSIONS AFFECTING WORK. DO NOT SCALE FROM ELECTRICAL PLANS. REFER TO ARCHITECTURAL, STRUCTURAL, AND MECHANICAL DRAWINGS FOR GUIDANCE AND VERIFICATION OF DIMENSIONS, CEILING HEIGHTS, DOOR SWINGS, ROOM FINISHES, AND LOCATION OF DUCTWORK, PIPES, EQUIPMENT, CABINET WORK, AND FURNITURE.
- INSTALL LIGHT FIXTURES PER ARCHITECTURAL REFLECTED CEILING PLANS.
- INSTALL WALL MOUNTED SWITCHES, OUTLETS, AND COMMUNICATION DEVICES IN STRICT COORDINATION WITH ARCHITECTURAL DETAILS, SECTIONS, AND ELEVATIONS.
- NO EXPOSED CONDUIT SHALL BE INSTALLED IN FINISHED SPACES.
- BRANCH CIRCUIT CONDUCTORS TO BE ROUTED ABOVE CEILING, NOT IN FLOOR SLAB OR CRAWL SPACE, UNLESS NOTED OTHERWISE.
- PROVIDE 3/4" CONDUIT WITH PULL CORD AND BELLED END, FROM TELEPHONE AND TELEVISION OUTLETS TO 6" ABOVE CEILING.
- LIGHT FIXTURES SHOWN HALF-SHADED ARE EMERGENCY AND ENERGIZED BY AN EMERGENCY BATTERY PACK. FIXTURES ARE TO BE NIGHT LIGHTS (UNSWITCHED) WHERE NO SWITCH IS SHOWN.
- SUPPORT ALL FIXTURES ACROSS CEILING TEES OR FROM STRUCTURE ABOVE. CEILING TILES OR PLASTER CEILING SHALL NOT SUPPORT FIXTURES.
- FINISHED FLOOR ELEVATIONS FOR OUTLETS AND OTHER DEVICES ARE TO CENTER OF BOX. IN ALL CASES WHERE MILLWORK IS PRESENT, BOTTOM OF BOX SHALL BE MINIMUM OF 2" ABOVE BACKPLASH, REGARDLESS OF DIMENSION SHOWN ON PLAN.
- WORK INDICATED ON PLANS REFLECTS ASSUMPTIONS CONCERNING EXISTING CONDITIONS BASED ON BEST AVAILABLE INFORMATION. NO ASSURANCE IS GIVEN THAT THESE ASSUMPTIONS ACCURATELY REFLECT ACTUAL JOB SITE CONDITIONS. BASE BIDS ON MODIFYING EXISTING CONDITIONS AS REQUIRED TO COMPLETE WORK AS INDICATED ON PLANS.
- FIRESTOPPING OF ELECTRICAL PENETRATIONS IN FIRE-RATED WALLS SHALL BE BY FIRESTOPPING CONTRACTOR PER SPECIFICATIONS SECTION 0270. ELECTRICAL CONTRACTOR SHALL MINIMIZE THE QUANTITY AND SIZE OF PENETRATIONS BY GROUPING CONDUITS AND CUTTING A NEAT HOLE OF THE CORRECT SIZE WITH A SAW. SLOPPY OR DESTRUCTIVE WORKMANSHIP SUCH AS MAKING A PENETRATION BY KNOCKING A LARGE AND/OR IRREGULAR HOLE WITH A HAMMER, IS NOT ACCEPTABLE.
- TEMPERATURE CONTROL/THERMOSTAT WIRING TO BE BY TEMPERATURE CONTROLS CONTRACTOR.
- HAY BRANCH SCHOOL - PROVIDE:
 - FOUR 4'-0" L x 2-LAMP FLUORESCENT STRIP FIXTURES WITH WIRE GUARDS (LITHONIA C-240-120-ES-WG9, OR APPROVED EQUIVALENT) SURFACE MOUNTED ON CEILING OF CRAWL SPACE, APPROXIMATELY 40'-0" ON CENTER.
 - 20A, 120/277V, SPST, PILET LIGHTED SWITCH (PASS & SEYMOUR 20AC1-RFL, OR APPROVED EQUIVALENT) MOUNTED 48" AFF. IN JANITOR'S CLOSET ADJACENT TO ACCESS DOOR, TO CONTROL LIGHTS.
 - 20A, 120V DUPLEX RECEPTACLE WITH WEATHERPROOF COVER PLATE, IN SURFACE MOUNTED BOX ON CEILING OF CRAWL SPACE, ADJACENT TO EACH LIGHT, UNSWITCHED.
 - GFI CIRCUIT BREAKER FOR CRAWL SPACE LIGHTS AND RECEPTACLES ON LVAA-10.

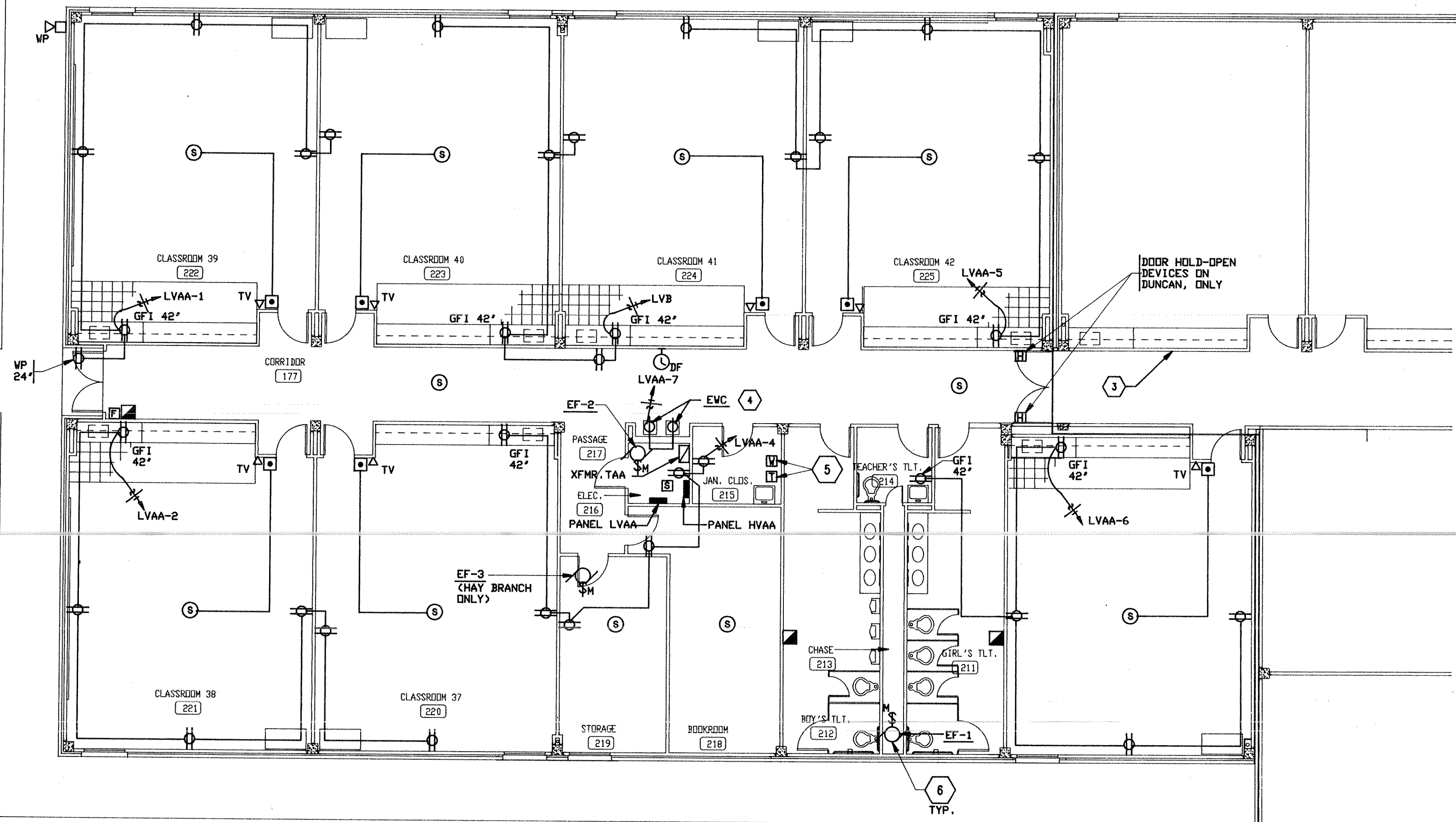

01 POWER PLAN - TYPICAL ALL SCHOOLS
 SCALE: 1/8" = 1'-0"

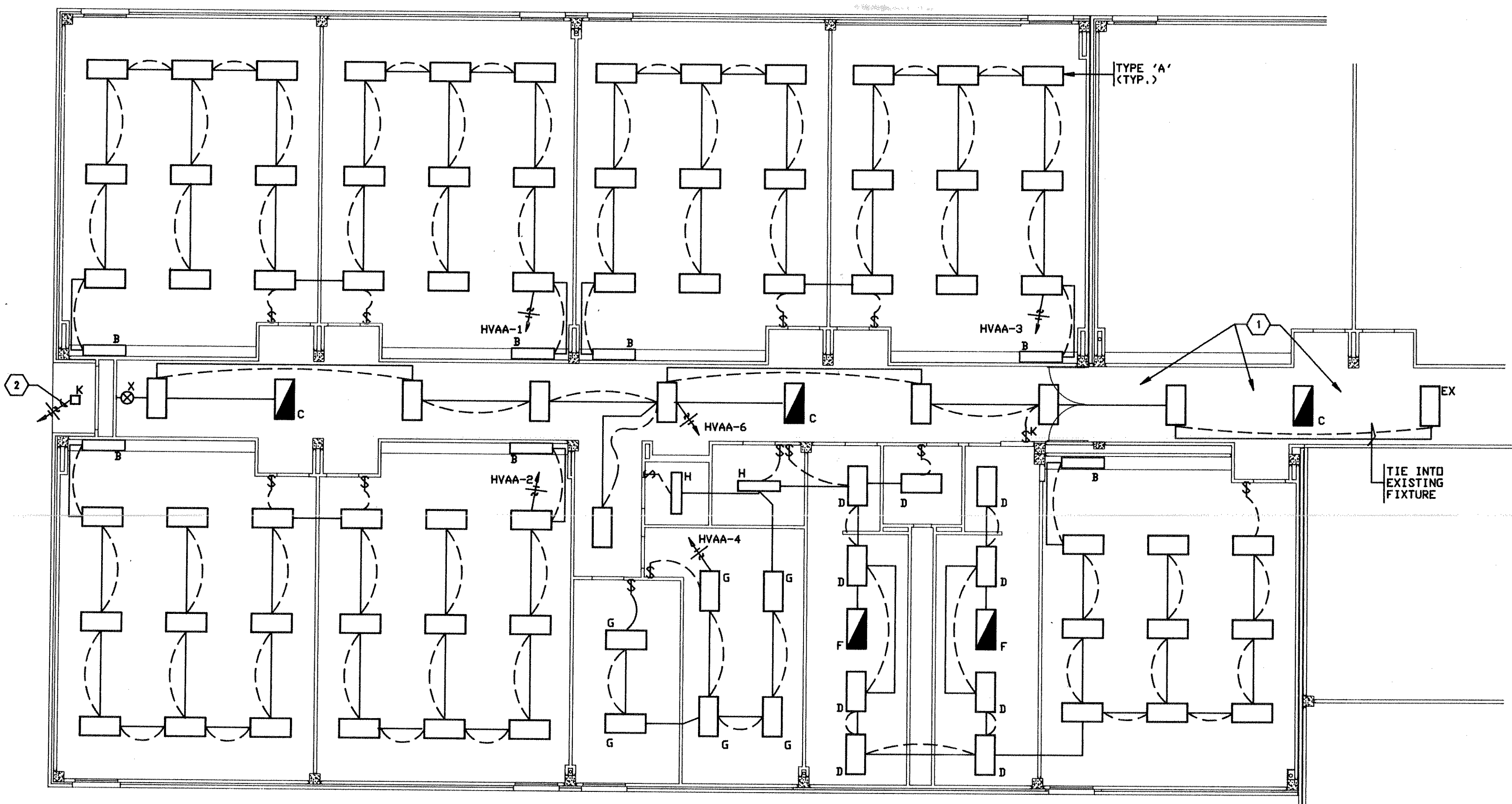

02 LIGHTING PLAN - TYPICAL ALL SCHOOLS
 SCALE: 1/8" = 1'-0"

PANELBOARD SCHEDULE							
PANEL HVAA		150A MLO		277/480V/4W/3PH/SN		SURFACE MOUNTED	
CKT. NO.	DESCRIPTION	LOAD WATTS	N	BKR. SIZE	BKR. SIZE	N	LOAD WATTS
1	18A, 2B LIGHTS	2546	1	20	20	1	2546
3	18A, 2B LIGHTS	2546	1	20	20	1	2546
5	SPARE	2000	1	20	20	1	1271
7	ROOF-TOP UNIT 1	2770	3	15	30	3	5000
9	SPARE	2770	3	15	30	3	5000
11	ROOF-TOP UNIT 2	2770	3	15	15	3	2770
13	ROOF-TOP UNIT 2	2770	3	15	15	3	2770
15	ROOF-TOP UNIT 3	2770	3	15	15	3	2770
17	ROOF-TOP UNIT 3	2770	3	15	15	3	2770
19	ROOF-TOP UNIT 4	2770	3	15	20	3	3878
21	ROOF-TOP UNIT 4	2770	3	15	20	3	3878
23	ROOF-TOP UNIT 5	2770	3	15	3	3	2000
25	ROOF-TOP UNIT 5	2770	3	15	3	3	2000
27	SPACE	2000	1	---	---	---	2000
29	SPACE	2000	1	---	---	---	2000
31	SPACE	2000	1	---	---	---	2000
33	SPACE	2000	1	---	---	---	2000
35	SPACE	2000	1	---	---	---	2000
37	SPACE	2000	1	---	---	---	2000
39	SPACE	2000	1	---	---	---	2000
41	SPACE	2000	1	---	---	---	2000

LOADS: 54642
TOTAL UNDIVERSIFIED: 116291 WATTS
SPARES & SPACES: 20000 WATTS
TOTAL DIVERSIFIED: 96291 WATTS
MIN. BREAKER SIZE: 145 AMPS

PANELBOARD SCHEDULE							
PANEL LVAA		60A MCB		120/208V/4W/3PH/SN		SURFACE MOUNTED	
CKT. NO.	DESCRIPTION	LOAD WATTS	N	BKR. SIZE	BKR. SIZE	N	LOAD WATTS
1	6 RECEPTACLES	1200	1	20	20	1	1200
3	6 RECEPTACLES	1200	1	20	20	1	1200
5	6 RECEPTACLES	1200	1	20	20	1	1000
7	2 EWC RECEPTACLES	1200	1	20	20	1	1200
9	ROOF OUTLETS	1000	1	20	20	1	1000
11	SPACE	1000	1	---	---	---	1000
13	SPACE	1000	1	---	---	---	1000
15	SPACE	1000	1	---	---	---	1000
17	SPACE	1000	1	---	---	---	1000
19	SPACE	1000	1	---	---	---	1000

LOADS: 10800
TOTAL UNDIVERSIFIED: 21400 WATTS
SPARES & SPACES: 5500 WATTS
TOTAL DIVERSIFIED: 15900 WATTS
MIN. BREAKER SIZE: 55 AMPS

WIRING DEVICE SCHEDULE			
SYMBOL	DESCRIPTION	SPECIFICATION	REMARKS
20	20 AMP 120/277 VOLT SINGLE POLE SWITCH SPST, SIDE & BACK WIRED	20A01-1	MOUNT AT 54" AFF UNLESS DESIGNATED OTHERWISE
20	20 AMP 120/277 VOLT SINGLE POLE MANUAL MOTOR STARTER WITH PILOT LIGHT AND THERMAL OVERLOADS	ALLEN-BRADLEY BULLETIN 600 IN NEMA 1 ENCLOSURE	MOUNT ON EQUIPMENT SERVED BY STARTER
20	HARD USE SPEC. GRADE, NEMA 5-20R	5352-1	MOUNT AT 12" AFF UNLESS DESIGNATED OTHERWISE
20	20 AMP 120 VOLT DUPLEX RECEPTACLE	5358-1	MOUNT AT 12" AFF UNLESS DESIGNATED OTHERWISE
20	20 AMP 120 VOLT GROUND FAULT INTERRUPTING DUPLEX RECEPTACLE	2091-FI	MOUNT HORIZONTALLY 12" AFF UNLESS DESIGNATED OTHERWISE
20	20 AMP 120 VOLT GROUND FAULT INTERRUPTING DUPLEX RECEPTACLE WITH WEATHERPROOF COVER PLATE	2091-FI WITH 1591-WP COVER PLATE	MOUNT AT 12" AFF UNLESS DESIGNATED OTHERWISE
20	TELEPHONE OR TELEVISION OUTLET	PROVIDE OUTLET BOX AND BLANK COVER PLATE	DESIGNATED OTHERWISE
20	COVER PLATES	SIERRA SERIES S-N, TYPE 302 STAINLESS STEEL	

DISTRIBUTION PANELBOARD SCHEDULE - DUNCAN					
PANELBOARD DPA		600A MLO		277/480V/3H/4W	
CKT. NO.	DESCRIPTION	LOAD WATTS	N	BREAKER FRAME	BREAKER TRIP
1	PANEL HVAA	96291	3	200	150
2	EXIST. XFMR.	39000	3	60	60
3	EXIST. HVC	66000	3	100	100
4	SPACE	66000	3	100	---
5	SPACE	66000	3	100	---
6	SPACE	66000	3	100	---

DISTRIBUTION PANELBOARD SCHEDULE - WILLOW SPRINGS & MOUNTAIN VIEW					
PANELBOARD DPA		600A MLO		277/480V/3H/4W	
CKT. NO.	DESCRIPTION	LOAD WATTS	N	BREAKER FRAME	BREAKER TRIP
1	PANEL HVAA	96291	3	200	150
2	PORTABLES	75000	2	200	200
3	SPACE	66500	3	100	---
4	SPACE	66500	3	100	---
5	SPACE	40000	3	60	---
6	SPACE	66000	3	100	---

DISTRIBUTION PANELBOARD SCHEDULE - HAY BRANCH					
PANELBOARD DPA		600A MLO		277/480V/3H/4W	
CKT. NO.	DESCRIPTION	LOAD WATTS	N	BREAKER FRAME	BREAKER TRIP
1	PANEL HVAA	96291	3	200	150
2	PORTABLES	75000	2	200	200
3	PORTABLES	38500	2	100	100
4	SPACE	66500	3	100	---
5	SPACE	66500	3	100	---
6	SPACE	40000	3	60	---

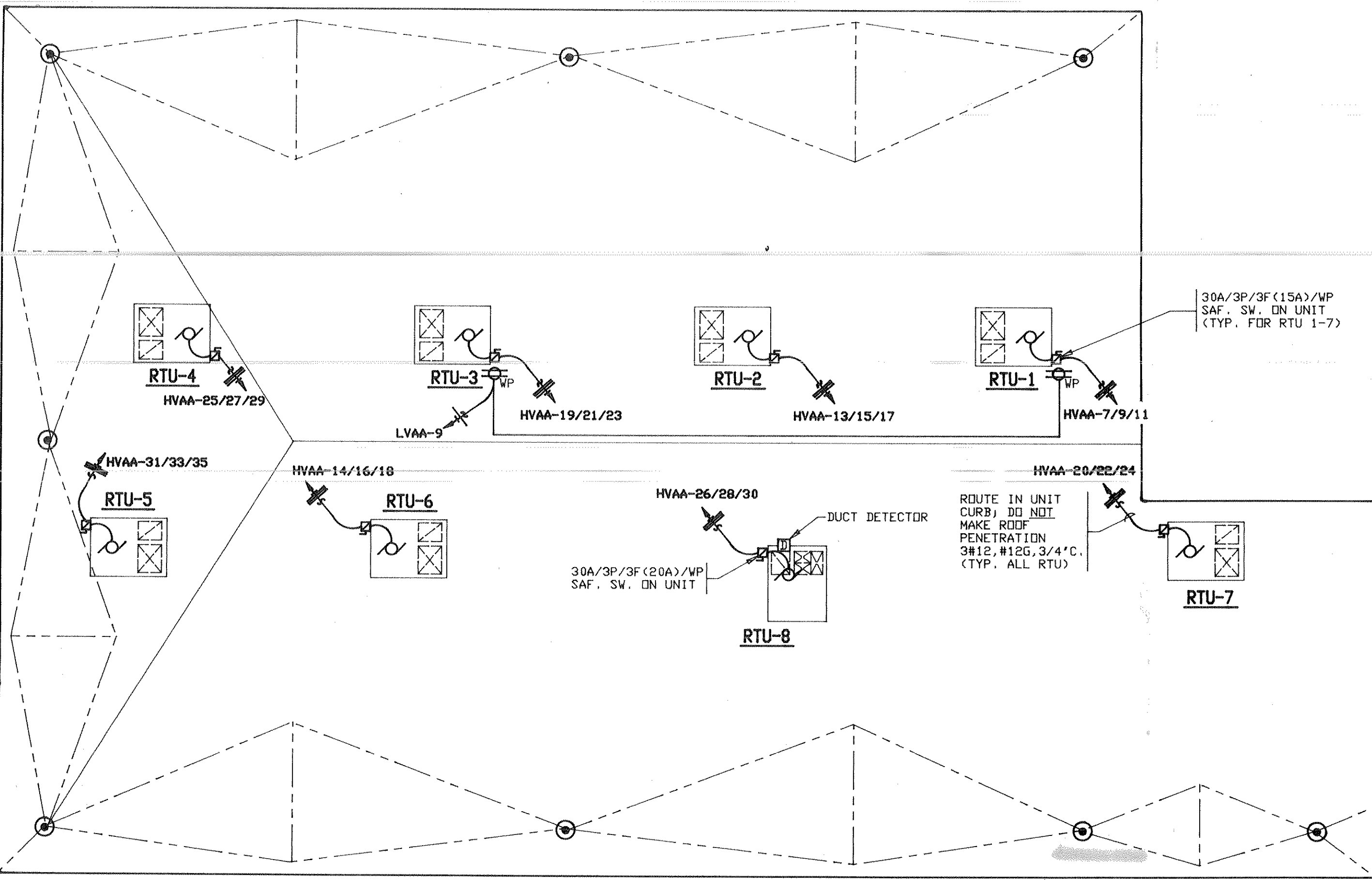

01 ROOF PLAN - ELECTRICAL
SCALE: 1/8" = 1'-0"

LIGHTING FIXTURE SCHEDULE						
LAMPS ARE THAT OF G.E. UNLESS NOTED OTHERWISE						
TYPE	MANUFACTURER AND CATALOG NO.	NO.	TYPE	WATTS	VOLTS	MOUNTING
A	2 X 4 TROFFER WITH 0.125" LENS LITHONIA 2GT-440-A12.125-277-ES	4	F40/RS/WM	34	277	LAY-IN
B	UNDER CABINET LIGHT WITH LENS NULITE 112-40HRS	1	F40/RS/WM	34	277	SURFACE
C	2 X 4 TROFFER WITH LENS & BATTERY LITHONIA 2GT-440-A12.125-277-ES-EL	4	F40/RS/WM	34	277	LAY-IN
D	2 X 4 TROFFER WITH 0.125" LENS LITHONIA 2SPF-240-A12.125-277-ES	2	F40/RS/WM	34	277	RECESSED
F	2 X 4 TROFFER WITH LENS & BATTERY LITHONIA 2SPF-240-A12.125-277-ES-EL	2	F40/RS/WM	34	277	RECESSED
G	2 X 4 TROFFER WITH 0.125" LENS LITHONIA 2GT-240-A12.125-277-ES	2	F40/RS/WM	34	277	LAY-IN
H	4'-0" L. CHANNEL WITH WIRE GUARD AND CEILING SPACER LITHONIA C-240-277-ES-1B-WG9	2	F40/RS/WM	34	277	SURFACE
K	VANDAL-RESISTANT CLEAR LENSED LIGHT FAIL-SAFE ISP-150	1	150A	150	120	SURFACE
X	MODULAR EXIT SIGN WITH BATTERY LITHONIA ES1R-277-ELN	2	INCLUDED	20	277	WALL

NOTES:
1. ENERGY-SAVING BALLAST FACTORY-INSTALLED; ENERGY-SAVING LAMPS FIELD-INSTALLED. COLOR RENDERING OF LAMPS (E.G. COOL WHITE) TO BE SAME AS EXISTING LAMPS IN SCHOOL.
2. FIXTURES TO BE AS MANUFACTURED BY LITHONIA, DAYRITE, OR METALUX, IN MODEL EQUIVALENT TO FIXTURE LISTED.
3. PROVIDE T-BAR SAFETY CLIPS.

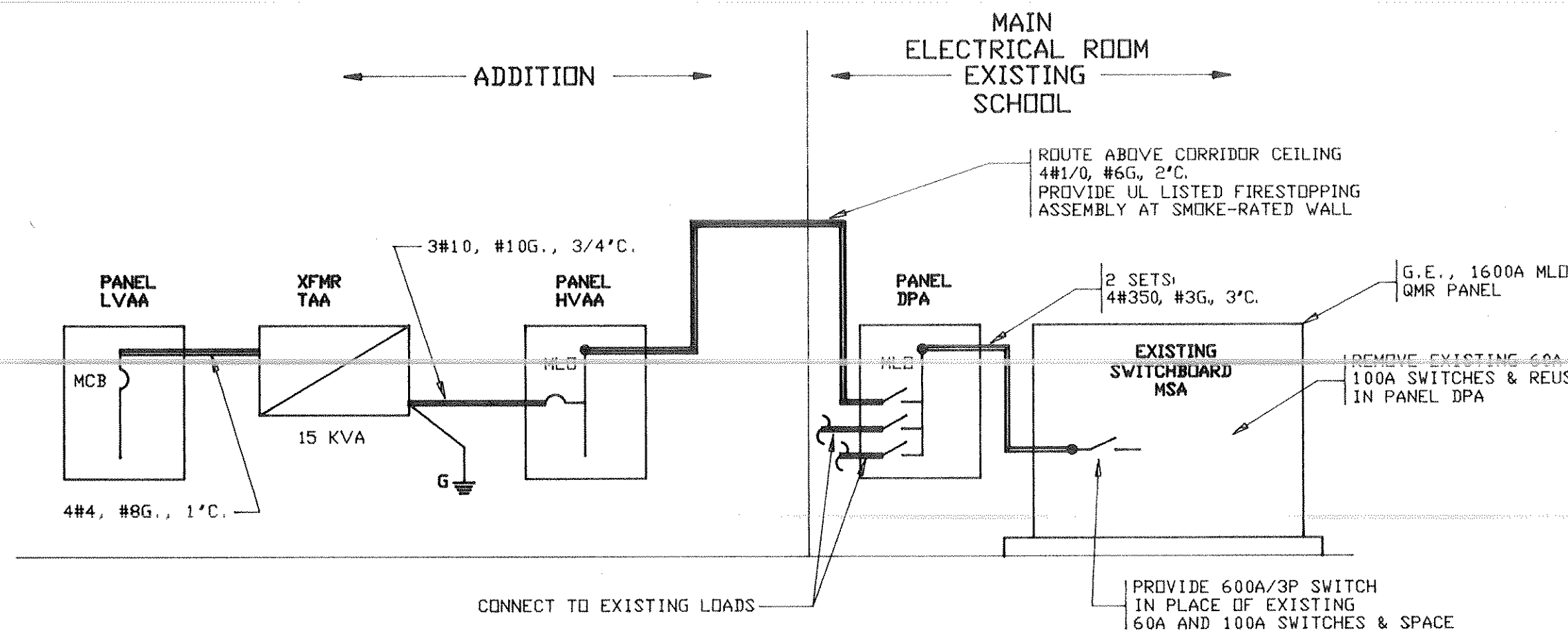

A RISER DIAGRAM - DUNCAN
SCALE: NONE

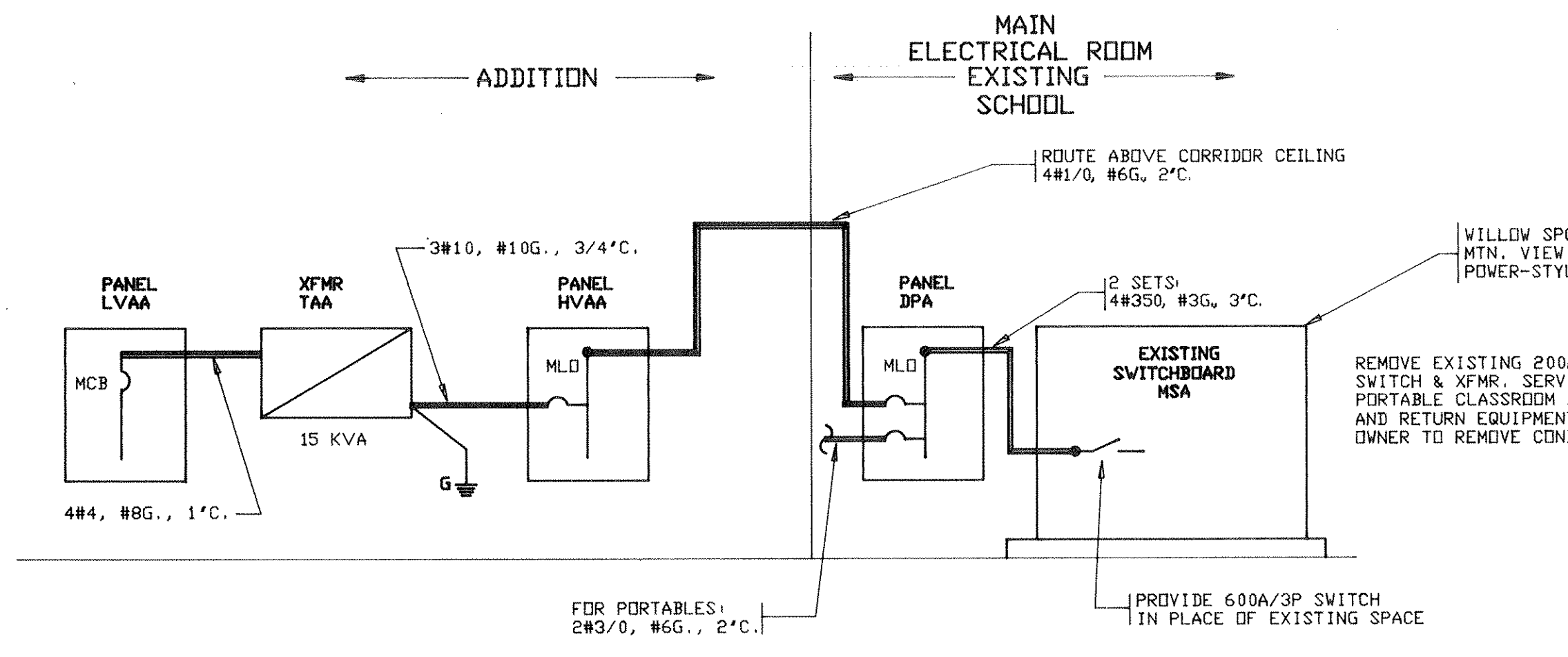

B RISER DIAGRAM - WILLOW SPRINGS & MOUNTAIN VIEW
SCALE: NONE

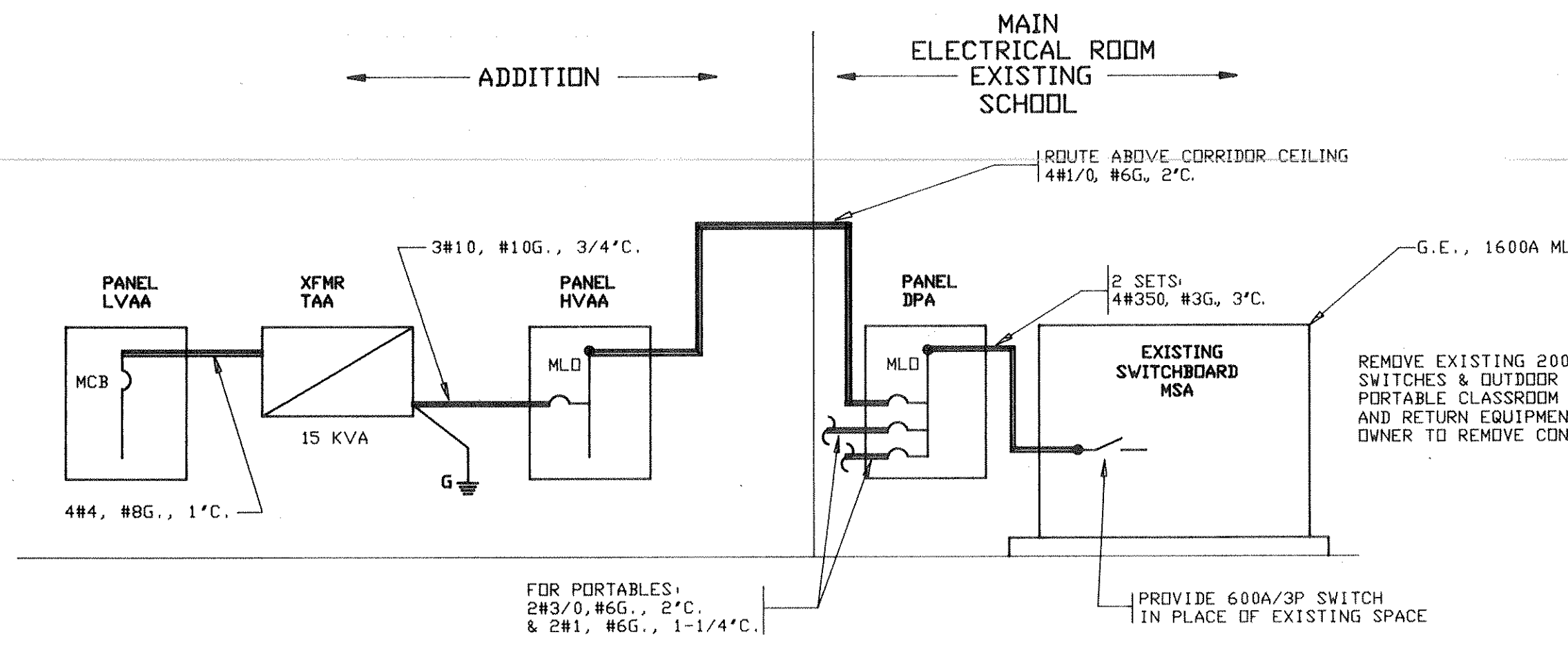

C RISER DIAGRAM - HAY BRANCH
SCALE: NONE

BLG
ARCHITECTS ENGINEERS PLANNERS
1600 W. 38TH STREET SUITE 100
JEFFERSON BUILDING AUSTIN, TX 78731 (512) 451-8881

TALEX, INC.
CONSULTING MECHANICAL-ELECTRICAL ENGINEERS
17-8-K

FOUR ELEMENTARY SCHOOL ADDITIONS
INDEPENDENT SCHOOL DISTRICT TEXAS
KILLEEN KILLEEN

PROJECT NUMBER
DATE 11-8-91

SHEET
E-3
OF 6